



EndurEnergy Systems, Inc.

Battery Unit

ESP-BU10

Residential Storage Product
Up to 10.24 kWh Battery Packs with BMS



Sense the Difference.
Live the Power.

Model	ESP-BU10
Dimensions (H x W x D)	45 x 22.3 x 5.7 inches (1143 x 566.4 x 144.8 mm)
Enclosure Weight	62 lb (28 kg)
Equipment Mounting Capacity	2 ESP-5K HL / 2 ESP-5100
Material	Steel
Color and finish	Gray and Black / Powder Coated
Protection Level	IP55
Warranty	10-Year
Compliance	UL9540, UL1973, CEC and SGIP pending

Configurations (ESP-5100)

Battery Packs In Parallel	1	2
Storage Capacity	100 Ah	200 Ah
Working Voltage	48V - 56V	48V - 56V
Nominal Energy	5.12 kWh	10.24 kWh
Weight (lb)	163.14 lb	264.55 lb
Weight (kg)	74 kg	120 kg

Configurations (ESP-5K HL)

Battery Packs In Parallel	1	2
Storage Capacity	100 Ah	200 Ah
Working Voltage	48V - 56V	48V - 56V
Nominal Energy	5 kWh	10 kWh
Weight (lb)	163.14 lb	264.55 lb
Weight (kg)	74 kg	120 kg

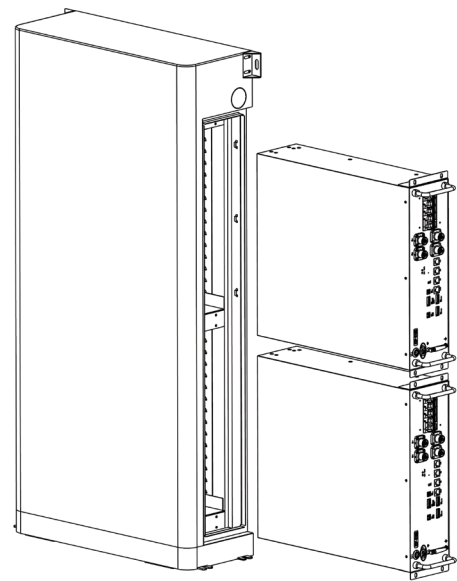

Exploded View

⚡ **OUTLAST. OUTPERFORM. ENDUR™ IT ALL.** ⚡

EndurEnergy Systems, Inc.

©2023 EndurEnergy Systems, Inc. All rights reserved. All specifications are subject to change without notice.
1-888-E²-ENDUR (323-6387) • endurenergy.com • sales@endurenergy.com • support@endurenergy.com

Rev. C 08/30/23



EndurEnergy Systems, Inc.

Mechanical Drawings

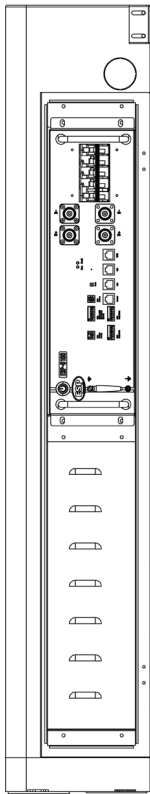

1 Battery Pack Configuration

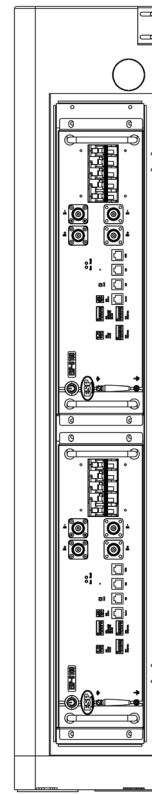

2 Battery Packs Configuration

⚡ **OUTLAST. OUTPERFORM. ENDUR™ IT ALL.** ⚡



ENDURENERGY SYSTEMS, INC.

FULLY-INTEGRATED BATTERY ENERGY STORAGE SYSTEMS



**SENSE THE DIFFERENCE.
LIVE THE POWER.**

Model	ESP-IBU10
Battery Module	2 * ESP-5100
Nominal Voltage (V)	51.2
Battery Capacity (Ah)	200
Nominal Battery Energy (kWh)	10.24
Working Voltage (V)	42-54
Charging Temp Range (° C)	0° - 45°
Discharging Temp Range (° C)	-10° - 55°
Calendar Life (Cycles)	>6000
Protection Level	IP55
Size L * W * H	717 * 358 * 1637 mm 28.2 * 14.1 * 64.4 inch

OUTLAST. OUTPERFORM. ENDUR™ IT ALL.

1-888-E²-ENDUR • endureenergy.com • sales@endureenergy.com • support@endureenergy.com



EndurEnergy Systems, Inc.



Battery Unit

ESP-BU15

Residential Storage Product
Up to 15.36 kWh Battery Packs with BMS



Sense the Difference.
Live the Power.

Model	ESP-BU15
Dimensions (H x W x D)	67.5 x 22.9 x 5.7 inches (1714.5 x 581.7 x 144.8 mm)
Enclosure Weight	82 lb (32 kg)
Equipment Mounting Capacity	3 ESP-5K HL / 3 ESP-5100
Material	Steel
Color and finish	Gray and Black / Powder Coated
Protection Level	IP55
Warranty	10-Year
Compliance	UL9540, UL1973, CEC and SGIP pending

Configurations (ESP-5100)			
Battery Packs In Parallel	1	2	3
Storage Capacity	100 Ah	200 Ah	300 Ah
Working Voltage	48V - 56V	48V - 56V	48V - 56V
Nominal Energy	5.12 kWh	10.24 kWh	15.36 kWh
Weight (lb)	171.96 lb	273.37 lb	374.78 lb
Weight (kg)	78 kg	124 kg	170 kg

Configurations (ESP-5K HL)			
Battery Packs In Parallel	1	2	3
Storage Capacity	100 Ah	200 Ah	300 Ah
Working Voltage	48V - 56V	48V - 56V	48V - 56V
Nominal Energy	5 kWh	10 kWh	15 kWh
Weight (lb)	171.96 lb	273.37 lb	374.48 lb
Weight (kg)	78 kg	124 kg	170 kg

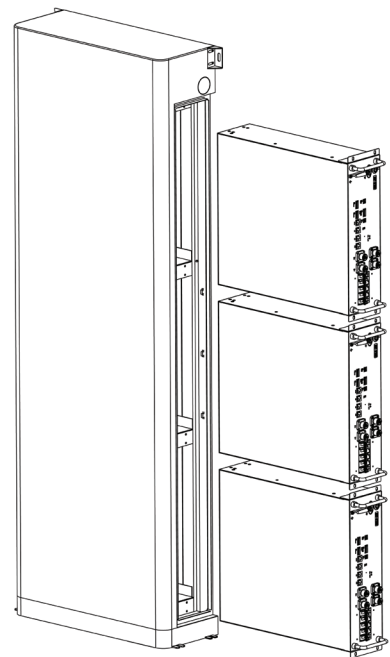

Exploded View

OUTLAST. OUTPERFORM. ENDUR™ IT ALL.



EndurEnergy Systems, Inc.

Mechanical Drawings

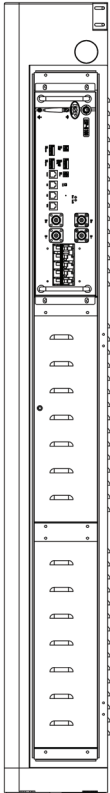

1 Battery Pack Configuration

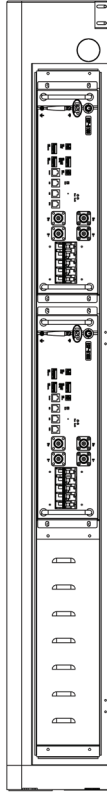

2 Battery Packs Configuration

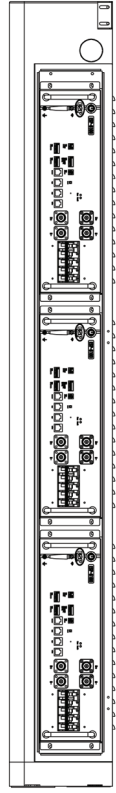

3 Battery Packs Configuration

⚡ **OUTLAST. OUTPERFORM. ENDUR™ IT ALL.** ⚡



EndurEnergy Systems, Inc.



Battery Unit

ESP-BU20

Residential Storage Product
Up to 20.48 kWh Battery Packs with BMS



Sense the Difference.
Live the Power.

Model	ESP-BU20
Dimensions (H x W x D)	48.2 x 22.9 x 14.1 inches (1224.3 x 581.7 x 358.1 mm)
Enclosure Weight	130 lb (59 kg)
Equipment Mounting Capacity	4 ESP-5K HL / 4 ESP-5100
Material	Steel
Color and finish	Gray and Black / Powder Coated
Protection Level	IP55
Warranty	10-Year
Compliance	UL9540, UL1973, CEC and SGIP pending

Configurations (ESP-5100)

Battery Packs In Parallel	1	2	3	4
Storage Capacity	100 Ah	200 Ah	300 Ah	400 Ah
Working Voltage	48V - 56V	48V - 56V	48V - 56V	48V - 56V
Nominal Energy	5.12 kWh	10.24 kWh	15.36 kWh	20.48 kWh
Weight (lb)	231.5 lb	332.9 lb	434.3 lb	535.7 lb
Weight (kg)	105 kg	151 kg	197 kg	243 kg

Configurations (ESP-5K HL)

Battery Packs In Parallel	1	2	3	4
Storage Capacity	100 Ah	200 Ah	300 Ah	400 Ah
Working Voltage	48V - 56V	48V - 56V	48V - 56V	48V - 56V
Nominal Energy	5 kWh	10 kWh	15 kWh	20 kWh
Weight (lb)	231.5 lb	332.9 lb	434.3 lb	535.7 lb
Weight (kg)	105 kg	151 kg	197 kg	243kg

⚡ OUTLAST. OUTPERFORM. ENDUR™ IT ALL. ⚡



EndurEnergy Systems, Inc.

Mechanical Drawings

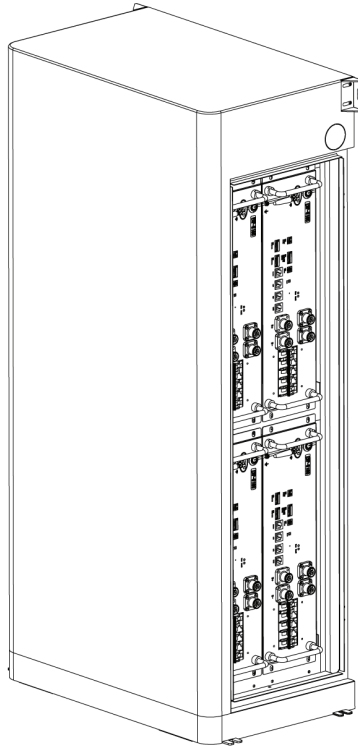

Isometric View

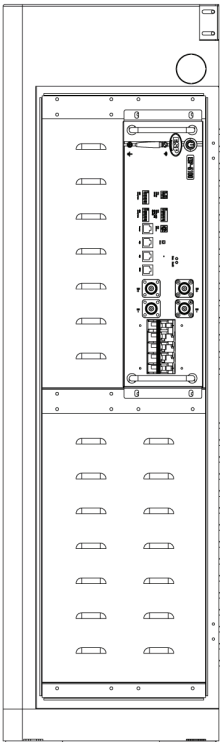

1 Battery Pack Configuration

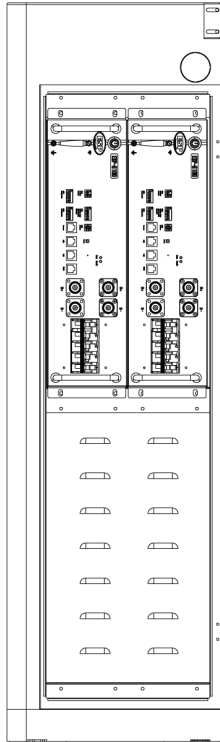

2 Battery Pack Configuration

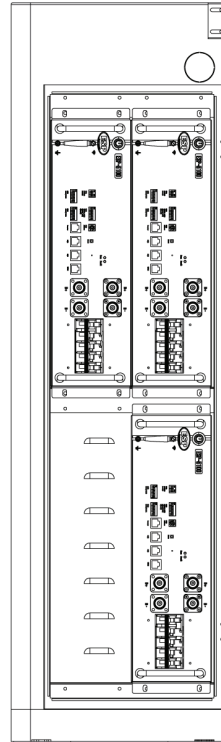

3 Battery Pack Configuration

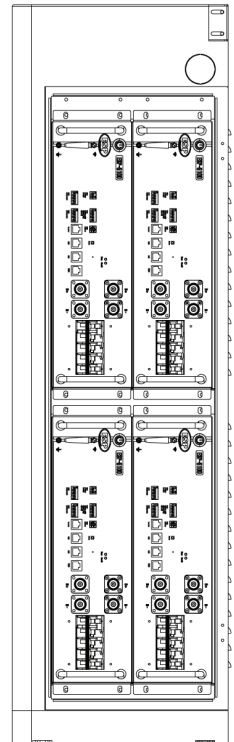

4 Battery Pack Configuration

OUTLAST. OUTPERFORM. ENDUR™ IT ALL.



ENDURENERGY SYSTEMS, INC.

FULLY-INTEGRATED BATTERY ENERGY STORAGE SYSTEMS



**SENSE THE DIFFERENCE.
LIVE THE POWER.**

Model	ESP-IBU20
Battery Module	4 * ESP-5100
Nominal Voltage (V)	51.2
Battery Capacity (Ah)	400
Nominal Battery Energy (kWh)	20.48
Working Voltage (V)	42-54
Charging Temp Range (° C)	0° - 45°
Discharging Temp Range (° C)	-10° - 55°
Calendar Life (Cycles)	>6000
Protection Level	IP55
Size L * W * H	722 * 358 * 2127 mm 28.4 * 14.1 * 83.7 inch

OUTLAST. OUTPERFORM. ENDUR™ IT ALL.

1-888-E²-ENDUR • endureenergy.com • sales@endureenergy.com • support@endureenergy.com



EndurEnergy Systems, Inc.

Battery Unit

ESP-BU30

Storage Product

Up to 30.72 kWh Battery Packs with BMS



Sense the Difference.
Live the Power.

Model	ESP-BU30
Dimensions (H x W x D)	67.5 x 26.7 x 15 inches (1715 x 677 x 383 mm)
Weight	176 lb (80 kg)
Equipment Mounting Capacity	6 ESP-5K HL / 6 ESP-5100
Material	Steel
Color and finish	Gray and Black / Powder Coated
Protection Level	IP55
Warranty	10-Year
Compliance	UL9540, UL1973, CEC and SGIP pending

Configurations (ESP-5100)

Battery Packs In Parallel	1	2	3	4	5	6
Storage Capacity	100 Ah	200 Ah	300 Ah	400 Ah	500 Ah	600 Ah
Working Voltage	48V - 56V	48V - 56V	48V - 56V	48V - 56V	48V - 56V	48V - 56V
Nominal Energy	5.12 kWh	10.24 kWh	15.36 kWh	20.48 kWh	25.6 kWh	30.72 kWh
Weight (lb)	277.8 lb	379.2 lb	480.6 lb	582 lb	683.4 lb	784.8 lb
Weight (kg)	126 kg	172 kg	218 kg	264 kg	310 kg	356 kg

Configurations (ESP-5K HL)

Battery Packs In Parallel	1	2	3	4	5	6
Storage Capacity	100 Ah	200 Ah	300 Ah	400 Ah	500 Ah	600 Ah
Working Voltage	48V - 56V	48V - 56V	48V - 56V	48V - 56V	48V - 56V	48V - 56V
Nominal Energy	5 kWh	10 kWh	15 kWh	20 kWh	25 kWh	30 kWh
Weight (lb)	277.8 lb	379.2 lb	480.6 lb	582 lb	683.4 lb	784.8 lb
Weight (kg)	126 kg	172 kg	218 kg	264 kg	310 kg	356 kg

⚡ **OUTLAST. OUTPERFORM. ENDUR™ IT ALL.** ⚡

EndurEnergy Systems, Inc.

©2023 EndurEnergy Systems, Inc. All rights reserved. All specifications are subject to change without notice.
1-888-E²-ENDUR (323-6387) • endurenergy.com • sales@endurenergy.com • support@endurenergy.com

Rev. B 08/30/23



EndurEnergy Systems, Inc.

Configurations (ESP-5KHL)

Battery Packs In Series	1	2	3	4	5	6
Storage Capacity	100 Ah	100 Ah	100 Ah	100 Ah	100 Ah	100 Ah
Working Voltage	48V - 56V	96V - 112V	144V - 168V	192V - 224V	240V - 280V	288V - 336V
Nominal Energy	5 kWh	10 kWh	15 kWh	20 kWh	25 kWh	30 kWh
Weight (lb)	277.8 lb	379.2 lb	480.6 lb	582 lb	683.4 lb	784.8 lb
Weight (kg)	126 kg	172 kg	218 kg	264 kg	310 kg	356 kg

Mechanical Drawings

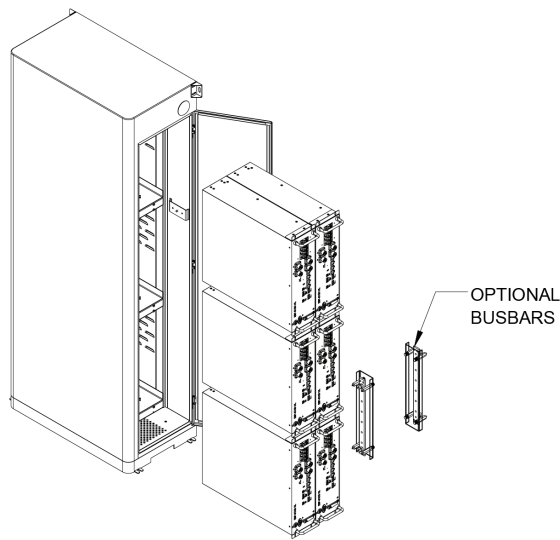

Exploded View

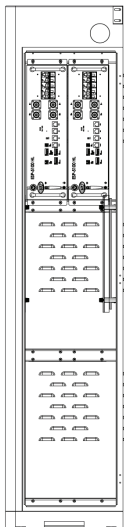

2 Battery Pack Configuration

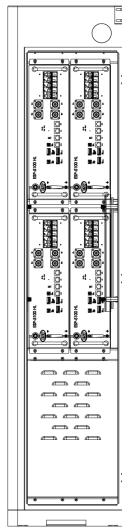

4 Battery Packs Configuration

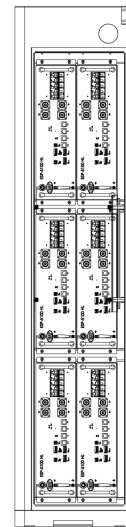

6 Battery Packs Configuration

⚡ OUTLAST. OUTPERFORM. ENDUR™ IT ALL. ⚡