

CHIKOUSA

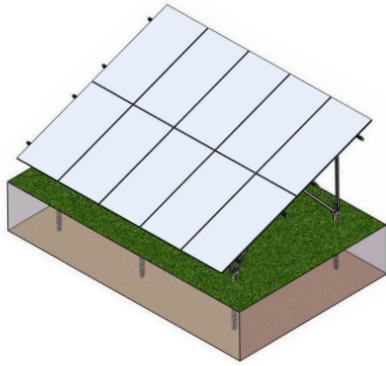

10 Panel Base

10 Panel High-Strength

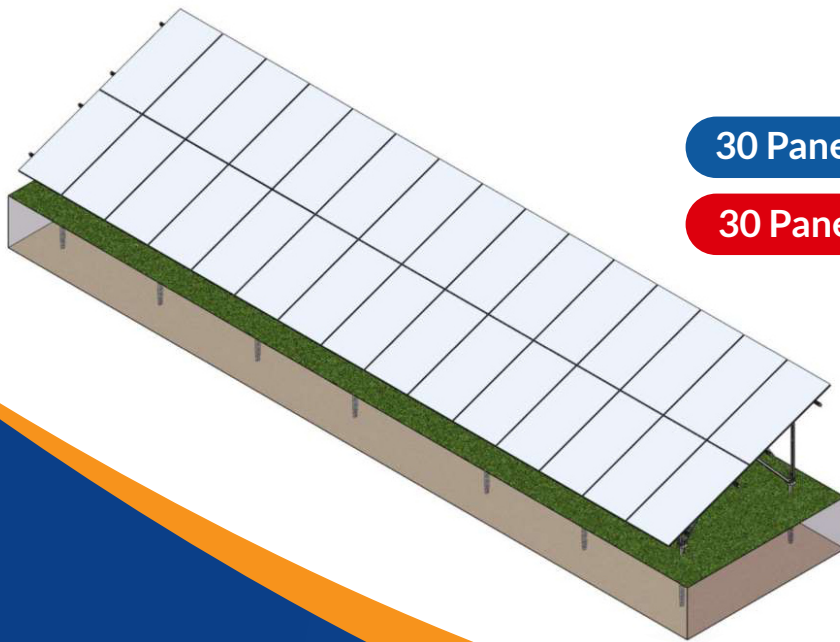

30 Panel Base

30 Panel High-Strength

Maximum Module Size
96" X 48"

CHIKOUSA CK-U2V

Steel Ground Mount

Installation Manual
Large Size Module

Version 2024.04.26



Intertek
Conforms to UL STD NO.2703

WARNING**Photovoltaic Hazard Control & Structural Building Safety**

(To Reduce Risk of Injury-Read and Follow All Instructions)

The installation of solar electric panels should only be performed by trained and qualified personnel. Unauthorized persons and children should not be allowed near the solar electric installation. Follow all permit, installation, and inspection requirements to include all applicable local, regional, and national electrical codes. Follow the safety precautions of all other system components.

Structural installation shall comply with all relevant local government standards, manufacturer's instructions and specification and safe building practices.

Follow the risk management process prior to commencing work-including identifying all potential hazards and assessed risks while eliminating or mitigating them from the jobsite.

Consult with all approved competent parties who will be involved in working on the jobsite. Develop safe working procedures for installing the structure and the solar panels using information obtained during the risk management process.

Wear all required Personal Protective Equipment during every phase of construction.

Always use equipment/tools/machinery safely and properly. Components are designed for "single use only", i.e. not for multiple construct and deconstruct projects.

Maintenance can only be performed by qualified personnel

- Any loose components or fasteners shall be re-tightened in accordance with these instructions
- Any components showing signs of damage shall be replaced immediately

ATTENTION

This Installation Guide and Attached Drawings and Layouts apply to 1 of 4 Ground Mount Versions. Please ensure you know which version you are installing. Utilize the appropriate drawings and layouts that correspond with the CHIKOUSA Ground Mount version you are installing.

The variables that impact which system you need include the number of panels being installed and the wind/snow load requirements within your geographic region. Higher wind and snow regions require additional hardware. The four Versions are:

1. 10 Panel Base
2. 10 Panel High-Strength
3. 30 Panel Base
4. 30 Panel High-Strength

**This Installation Guide Is For Large Size Modules With
A Length No Greater Than 96" & A Max Width Of 48"**

Easy To Confirm Model Needed By Determining Geographic Wind and Snow Load Requirement

10 PANEL MOUNT

Potrait	Standard Strength	Large Format Module
----------------	--------------------------	----------------------------

Allowable Rail Span (ft.) based on Wind Speed and Ground Snow Load

20 DEGREES	Wind Speed	Ground Snow Loads				
		0 psf	20 psf	40 psf	60 psf	80 psf
	90 MPH	8	7	5	4	-
100 MPH	7	6	4	-	-	
115 MPH	5	5	4	-	-	
130 MPH	4	4	4	-	-	
150 MPH	-	-	-	-	-	

10 Panel Base = 4 Beam Sets

10 Panel High-Strength = 5 Beam Sets

Easy To Confirm Model Needed By Determining Geographic Wind and Snow Load Requirement

30 PANEL MOUNT

Potrait	Standard Strength	Large Format Module
----------------	--------------------------	----------------------------

Allowable Rail Span (ft.) based on Wind Speed and Ground Snow Load

20 DEGREES	Wind Speed	Ground Snow Loads				
		0 psf	20 psf	40 psf	60 psf	80 psf
	90 MPH	8	7	5	4	-
100 MPH	7	6	4	-	-	
115 MPH	5	5	4	-	-	
130 MPH	4	4	4	-	-	
150 MPH	-	-	-	-	-	

30 Panel Base = 10 Beam Sets

30 Panel High-Strength = 12 Beam Sets

Always use the most recent version of the installation manual before installing your CHIKOUSA Steel Ground Mount. The installation manual is subject to change without notice. Please consult with CHIKOUSA to ensure you are utilizing the most up to date version of the Install Manual.

BRIEF DESCRIPTION

The CHIKOUSA Steel Ground Mount is a sturdy solar ground mount solution that can accommodate modules in a 10 or 30 count configuration. This structure can be installed with a 2-man crew, without the need for any heavy duty tools or equipment. The installation should always be completed by trained professionals and/or qualified individuals who have been adequately instructed and trained about the tasks involved with the installation, including the usage of protective devices, protective measures, relevant provisions, safety regulations and local operating site conditions and have proven competence in all areas of the installation.

Please carefully read this installation manual and all other applicable documents before starting your installation. Please contact CHIKOUSA with any questions that you may have.

MAINTENANCE

1. If signs of rust appear, take steps to remove the rust and paint the affected areas.
2. Check the bolts once a year ensuring all connections are secure, and after any major storm or weather occurrence.
3. All components showing signs of damage that compromise the safety of the structure shall be replaced immediately.

WARNING

If any structural component of the system is damaged it must be replaced immediately.

FOOTER WARNING

Anyone who plans to dig should call 811 or visit their state's 811 center's website a few business days before digging to request that the approximate location of buried utilities be marked with paint or flags so that you don't unintentionally dig into an underground utility line.

MEASUREMENT NOTE

Some measurements have been converted from MM to inches. The accuracy of a measurement can vary slightly from MM to inches. All measurements are available in MM for detailed accuracy. The most critical measurement required is the distance between the front and rear leg both North to South and East to West. These measurements dictate the attachment locations for the Ground Mount System.

REQUIRED INSTALLATION TOOLS

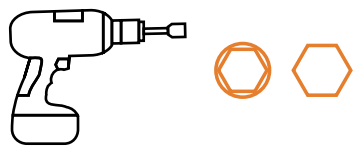

DRILL



GLOVES



CHALK LINE

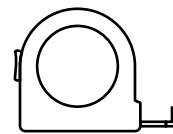

TAPE MEASURE



RUBBER Mallet



LASER LEVEL



SAFETY GLASSES



CONSTRUCTION STRING

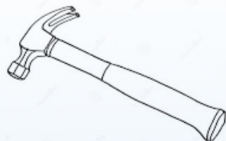

HAMMER

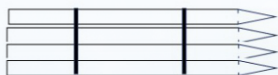

CONSTRUCTION STAKES



SMALL MAGNETIC LEVEL

I Main Components



Front V Leg

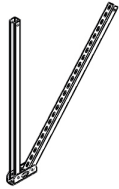

Rear V Leg

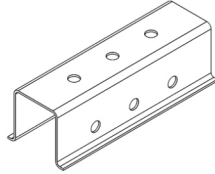

Beam



Beam Splice



Strengthen Pipe

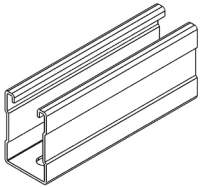

Rail

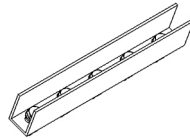

Rail Splice Kit

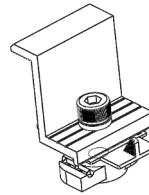

End Clamp

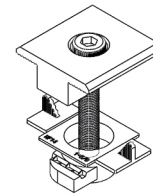

Mid Clamp

II Ground Mount Installation Warning

Safety Notes:



Warning:

Anyone who plans to install the CHIKOUSA Ground Mount into bare earth should call 811 or go to your state's 811 center's website a few business days before installing any attachment into the ground to request that the approximate location of buried utilities to be marked with paint or flags so that during installation you don't unintentionally encounter an underground utility line.

Utilizing the 811 service protects you and your community! Hitting a buried line while installing the CHIKOUSA Ground Mount can disrupt utility service, cost money to repair, or cause serious injury or death. Always contact your 811 center, wait the required time for utilities to respond to your request, and ensure that all utilities have responded to your request before beginning your installation.

You will need to know the address of where you plan to install your ground mount, including the county and nearest cross streets, as well as the type of project you are completing and the exact area on the property where you will be planning on installing the Ground Mount. Whether you call 811 or make your request online, you will need the same information.



Warning:

Appropriate safety equipment must be worn When installing the Ground Mount System.



III Installation Rule

Installation of the CHIKOUSA Ground Mount shall comply with all relevant local government standards, manufacturer's specifications and safe building practices. The mounts that the ground mount is connected to shall conform to the relevant local government standards.

- ◆ Follow the risk management process prior to commencing work – that is, identify all the on site hazards, assess their risks and eliminate or control them.
- ◆ Consult with those involved in the work and communicate all identified risks and overall project build scope.
- ◆ Develop safe work procedures for installing the Ground Attachments, the Ground Mount, and the Solar Panels using information from the risk management process, which would include reviewing the following information:
 - Consulting with you local 811 service to know where all underground utilities are located
 - Provide appropriate information and training to those involved in performing the work.
 - Provide appropriate tools and personal protection equipment (PPE).
 - Ensure that a system is in place to prevent or arrest falls.
 - Ensure there are adequate first aid facilities.
 - Ensure all employees and anyone associated with working on the project are aware of the emergency procedures.

IV Notice

1. Max Span 9'
(Review current span charts and apply all applicable site conditions to include wind, snow, module size, tilt, etc. to determine recommended site span calculations.)
2. Max. Rated Current: 30A
3. Minimum design load for Chiko CK-U2V STEEL GROUND MOUNT mounting system:
 - a) Downward Pressure - 10 psf allowable load
 - b) Upward Pressure - 5 psf allowable load
 - c) Down-Slope Load - 5 psf allowable load
4. This ground mount system is used for in ground mounting
5. This racking system has been tested and evaluated to UL 2703 for Bonding, grounding, mechanical loading and fire classification, and may be used to ground and/or mount PV modules listed to UL 1703 or UL 61730.

V Components

1. Front & Rear V-Legs
2. Rail & Beam Connection
3. Rail Splice
4. End Clamp
5. Mid Clamp
6. Strengthening Pipe
7. Ground Screw/Trident Mount
8. Beam Splice
9. Rai

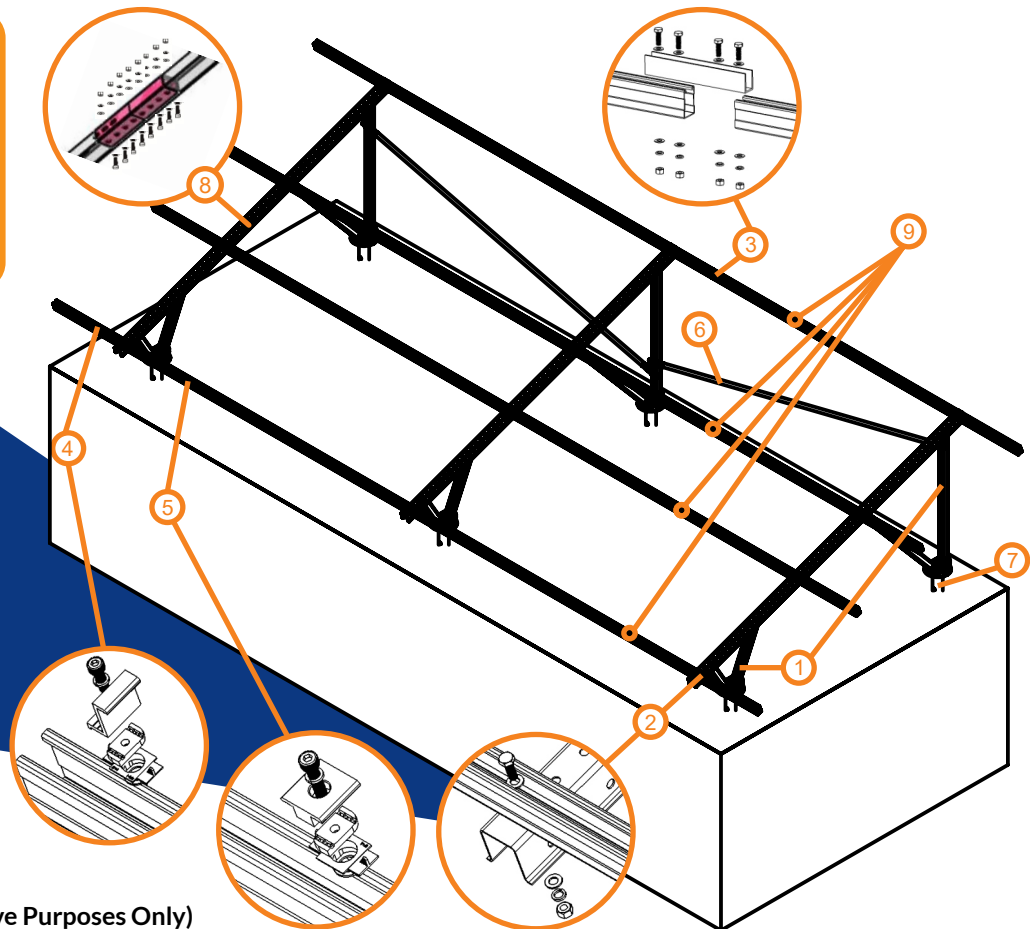

(For Illustrative Purposes Only)

VI Installation Steps

Insert Ground Screw, Trident Mount, or other approved ground mount attachment into the ground according to drawing.

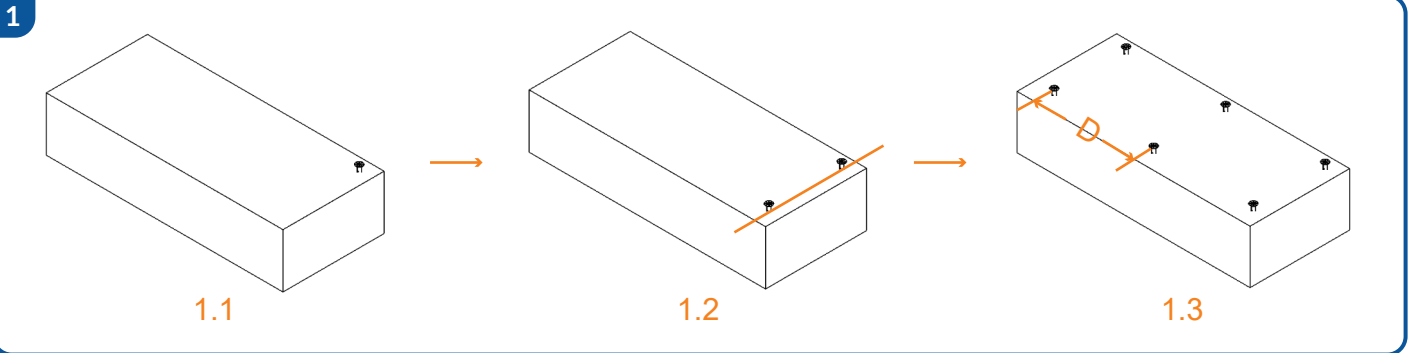

Connect 2 sections of the top beams (78.7" & 82.6") with the Beam Splice (15.7") connect the beams with the M10x80 Hardware, once 2 beams are spliced together the new total beam length will be 161.4" Mark the 82.6" section of Beam with a clearly visible mark on beam that can be seen from a top view. Ensure that the marked portion of the beam is installed on the high side or the side with the longest legs. (The marked portion was originally 82.6")

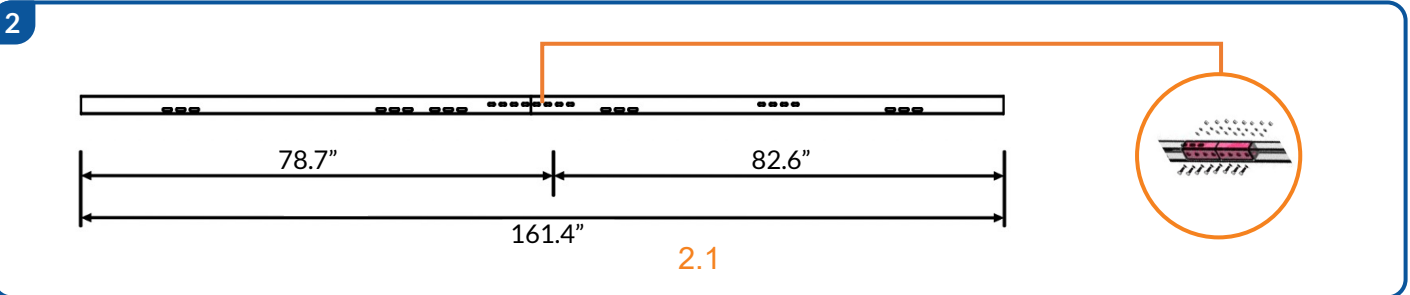

Install the beam on front leg and rear leg by hex bolts M10*80 (1 flat washer, 1 spring washer, 1 nut).

M10: tighten torque is 30N.m;
safe torque is 40N.m;

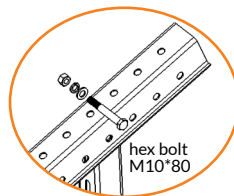

The front V leg and rear V leg are pre-assembled with V bases by hex bolts M10*80 (1 flat washer, 1 spring washer, 1 nut).

M10: tighten torque is 30N.m; safe torque is 40N.m;

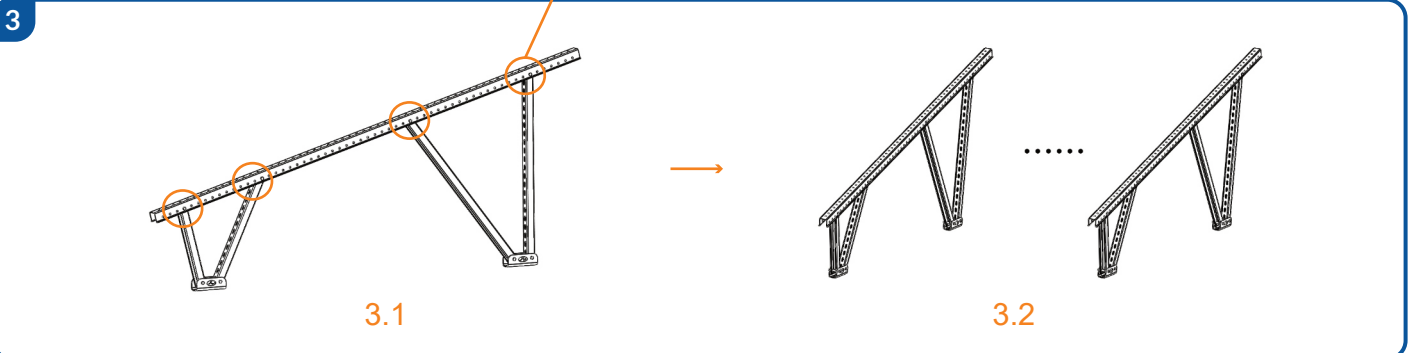

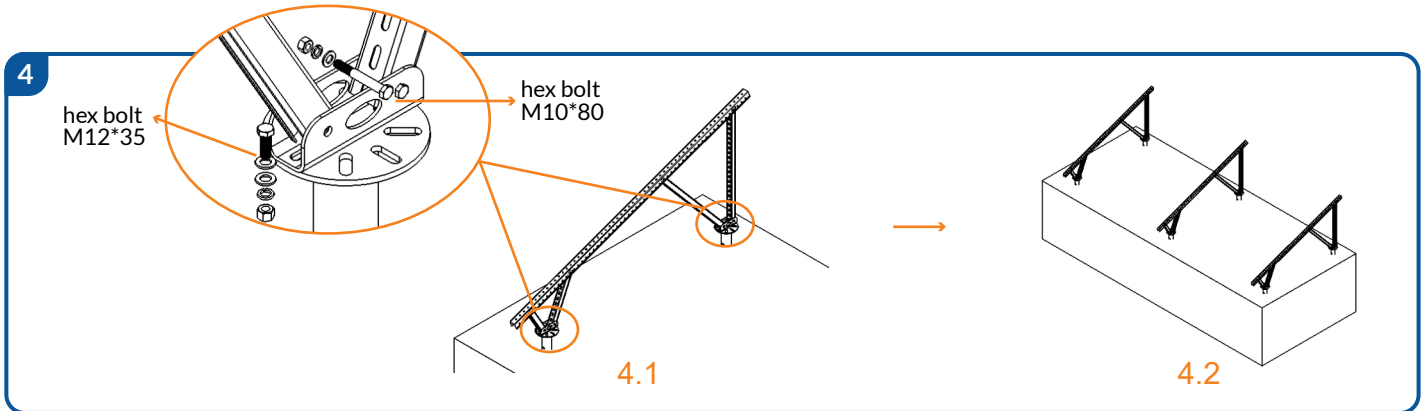

Connect the V leg bases to ground screws by hex bolts M12*35 (2 flat washers, 1 spring washer, 1 nut);
M12: tighten torque is 50N.m; safe torque is 55N.m;

Use the same attachment method and torque specs when utilizing the Trident Mount. When connecting bases to concrete using anchor bolts follow the specific anchor bolt installation instructions.

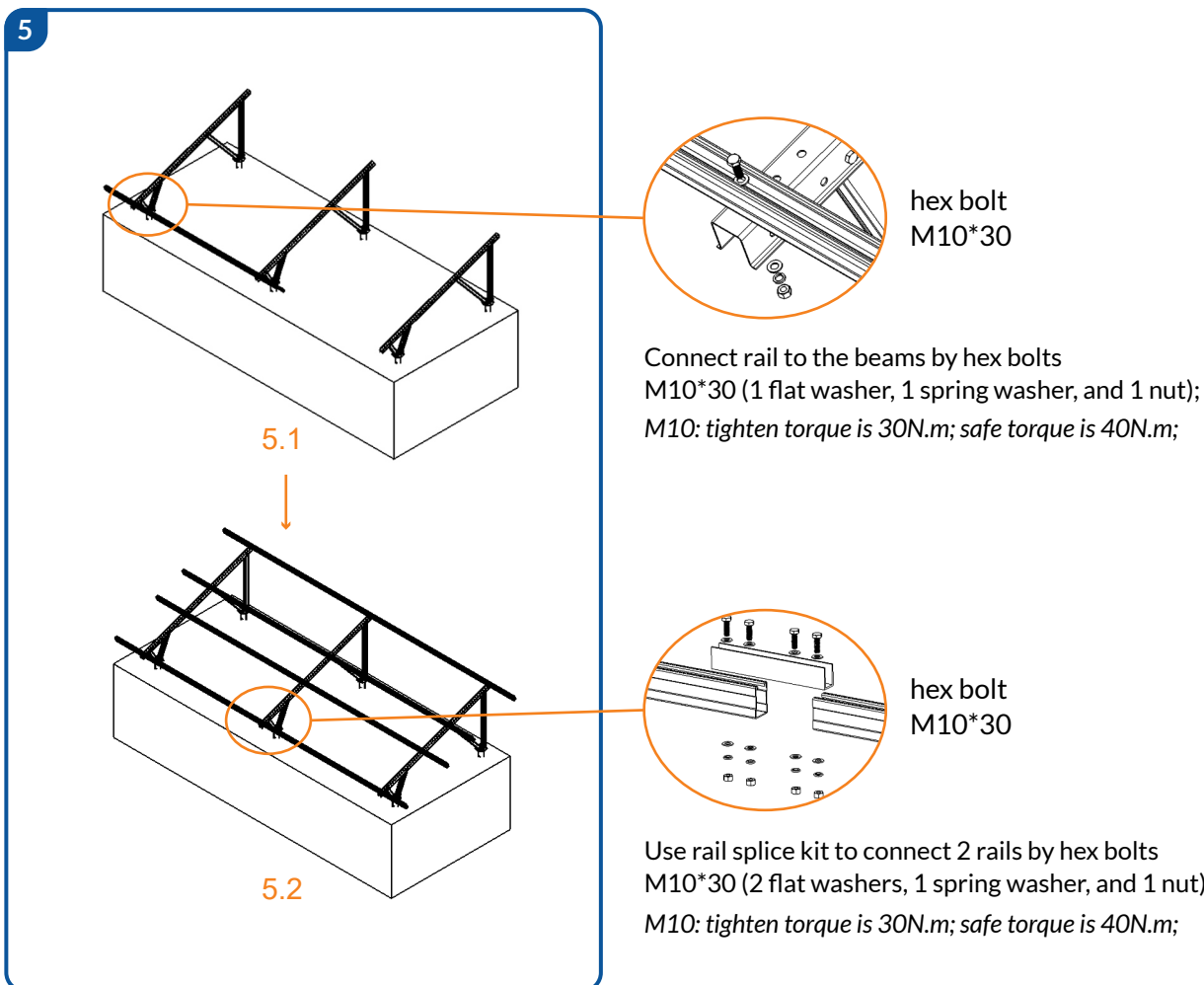

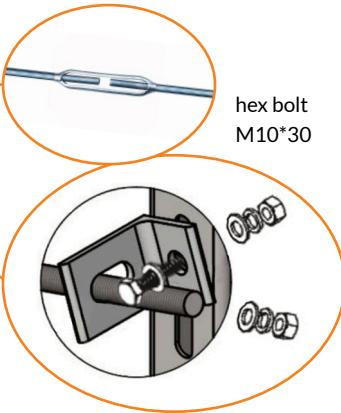
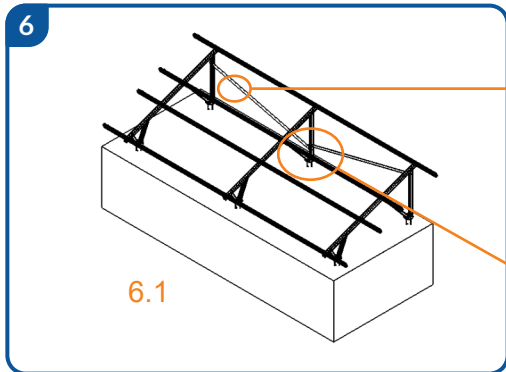

Assemble the Strengthening Pipes & Orchid Bolt to the Structure

Connect the 78.7-inch pipe section to the 39.4-inch pipe section using an orchid bolt in the center. Each end of the strengthening pipes will be threaded and the Orchid Bolt is threaded. Attach the strengthening pipe fix kits (small L-angle brackets) to the rear opposing V-Legs. Use the M10*30mm Bolt Kits to mount the brackets at opposing heights (e.g., one high and one low) Slide the assembled strengthening pipe through the holes in the Strengthening Pipe Kits (Small L-angle brackets). Secure both ends of the pipe using an M10 washer and nut.

Important: Trimming for Custom Spans

If your configuration uses a smaller spans, you may need to cut the threaded ends of the strengthening pipes to fit. Measure Twice: Measure the required length and cut all four ends equally to maintain balance. Thread the nut onto the pipe before cutting. Removing the nut after the cut will automatically repair and "re-establish" the threads.

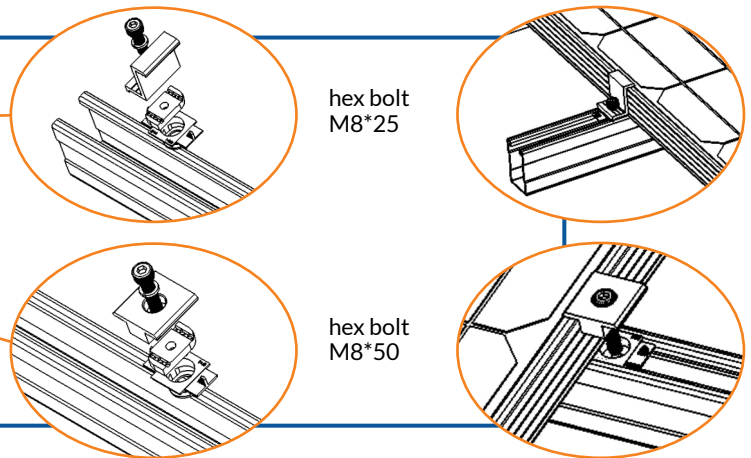
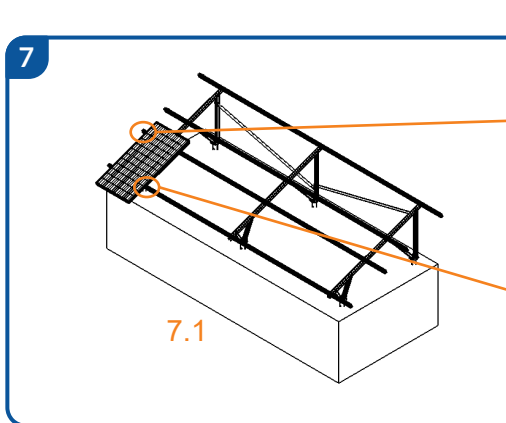

Install panels onto rails by fastening mid and end clamps.

Note: End clamps by inner hex bolts M8*25 (1 spring washer, 1 plastic steel nut);
Mid clamps by inner hex bolts M8*50 (1 spring washer, 1 plastic steel nut).

M8: tighten torque is 15N.m; safe torque is 20N.m;

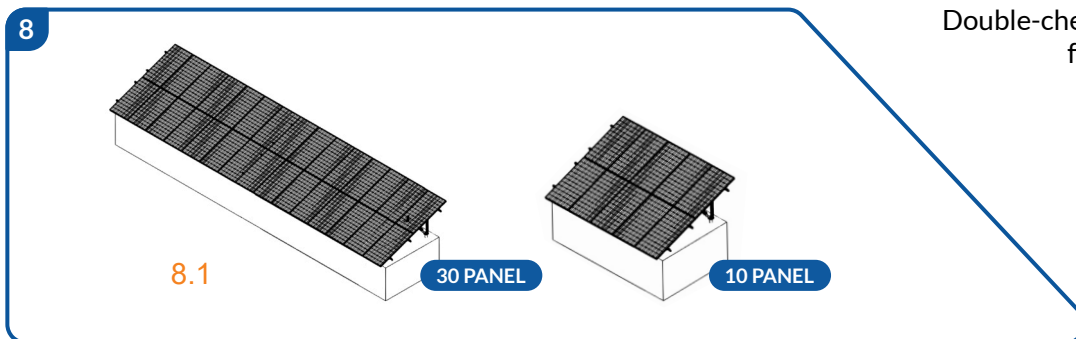

Double-check to make sure all bolts are fastened tight after installing all the panels.

VII Grounding System

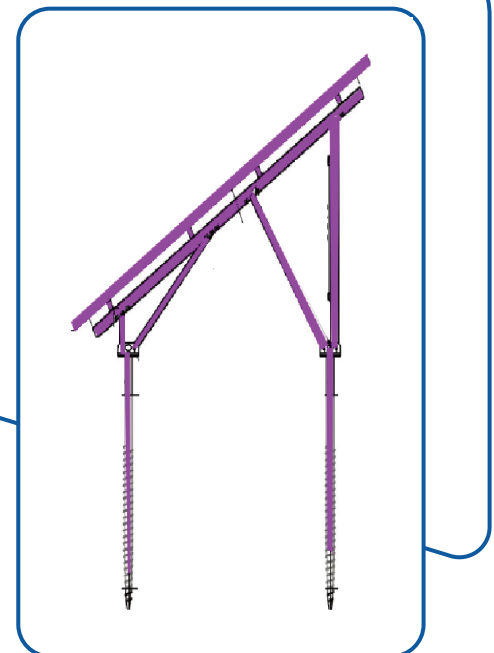
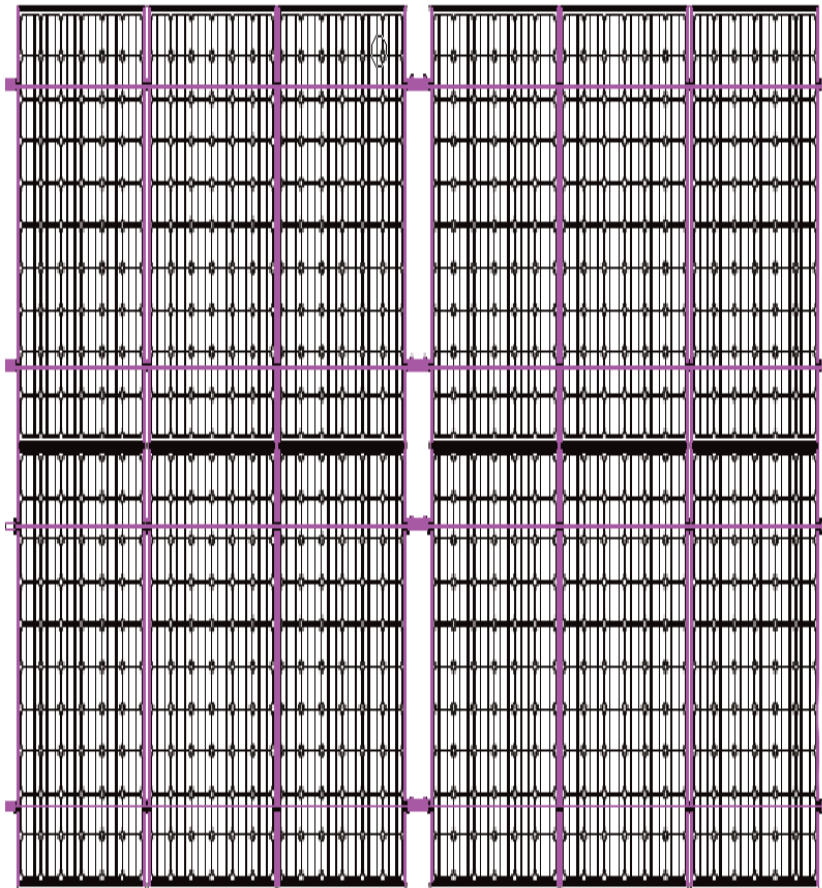

The grounding function of the whole mounting system connections is achieved by the following steps

1. Grounding Mid Clamp and Grounding End Clamp: Grounding & Solar Panel
2. Rail Splice Kit : Connect two rails
3. Beam Splice Kit : Connect two Beams
4. SUS Bolt and Nut: All mounting system connected
5. Ground screw: connect the mounting system to the ground
6. Grounding Lug
7. Copper wire (or other steel products): connect the mounting system to the ground (if not ground screw foundation, such as concrete)

Grounding Lugs are intended for use with one solid or stranded copper wire, conductor size range 10-6 AWG following local municipal and/or AHJ guidelines

CONTINUING MAINTENANCE

- a) Any loose components or fasteners shall be re-tightened in accordance with these instructions
- b) Any components showing signs of damage that compromise safety shall be replaced immediately

FOR SINGLE USE ONLY

Bonding and grounding devices, are "For single-use only", NOT multiple use) Module removal may disrupt the bonding path and could introduce the risk of electric shock. To ensure that the bonding path remains intact, additional steps may be necessary; qualified persons should follow the instructions in this manual."

Scenarios that could result in a disruption of the bonding path are irregularly-shaped arrays, arrays consisting of individual rows or any other scenario where module removal could disrupt the bonding path.

Installation of Grounding Lug

Install a grounding lug (500mm from the rail end) on to each rail line edge with an inner hex bolt M8*25 and a stainless steel nut, then cross 8.4mm² (greater than or equal to 8AWG) copper wire through all the grounding lugs (fixed by M8*20 inner hex bolt), finally connect copper wire to the ground. The grounding lug has grounding function when fastened tight to connect rail and copper wire. M8 Torque: 15~20N.m

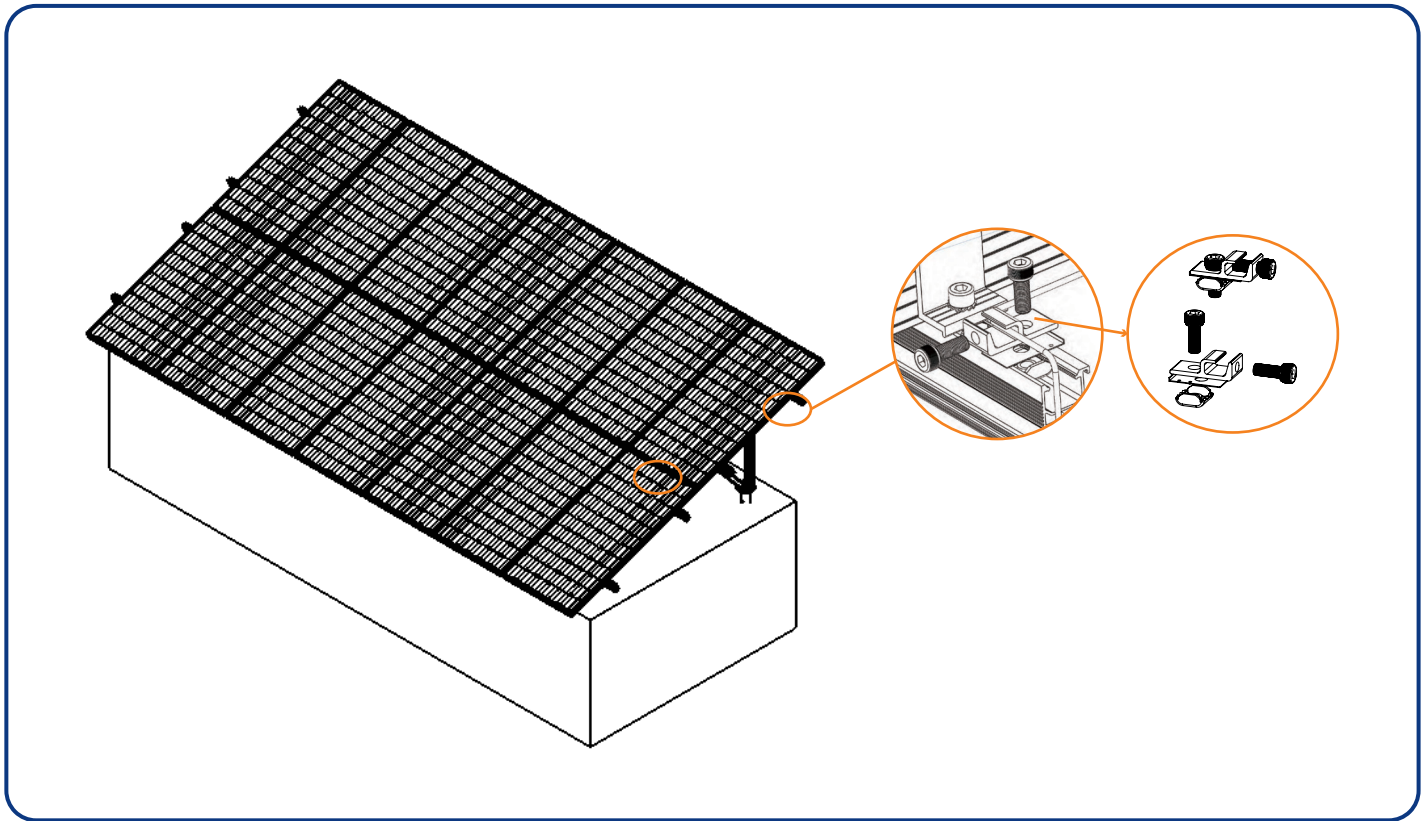

Electrical Characteristics of AWG Copper Wire

AWG	Diameter [inches]	Diameter [mm]	Resistance [Ohm / 1000ft.]	Resistance [Ohm / km]	Max Current [Amperes]	Max Frequency for 100% skin depth
6	0.162	4.1148	0.3951	1.295928	37	1100 Hz
7	0.1443	3.66522	0.4982	1.634096	30	1300 Hz
8	0.1285	3.2639	0.6282	2.060496	24	1650 Hz
9	0.1144	2.90576	0.7921	2.598088	19	2050 Hz
10	0.1019	2.58826	0.9989	3.276392	15	2600 Hz

Authorized to Mark

Equipment and components are authorized to be marked with the manufacturer's name, trade name, trademark or other descriptive marking which identifies the organization responsible for The product, part number, and/or model number.

System Model No : CK-U2V

Max. Rated Current : 30A

Max. Size : 6000mm

System Fire Class Rating : NA

See Installation Instructions for Installation Requirements to achieve a Specified System UL2703 Grounding with this Product.

Manufactured Add : No 680 Xingwen Rd. Jiading dist.
Shanghai 201815, China

Production Date : 20230315

Design Load :

- a) Downward Pressure - 10 psf
- b) Upward Pressure - 5 psf
- c) Down-Slope Load - 5 psf



Panel Mounting Start Location for 10 and 30 Panel Systems

10 Panel System

$$\frac{\text{Panel Width}}{\text{# of Panels in Row Spacing}} \times 5 = ? + 6" = \frac{\text{Total Panel Width Plus Clamp Distance}}{\text{Total Rail Length}} - 248" = ? \div -2 = \frac{\text{Distance From End of Rail to 1st Panel}}$$

Example: (Using 44.6" wide module)

$$44.6 \times 5 = 223 + 6" = 229" - 248" = -19 \div -2 = 9.5"$$

9.5 Inches is the distance from the end of the Rail to the 1st Panel Edge Installed

Max Panel Width 48.6"

Authority Having Jurisdiction (AHJ) to provide max wind and snow load requirements for install location

30 Panel System

$$\frac{\text{Panel Width}}{\text{# of Panels in Row Spacing}} \times 15 = ? + 16" = \frac{\text{Total Panel Width Plus Clamp Distance}}{\text{Total Rail Length}} - 744.1" = ? \div -2 = \frac{\text{Distance From End of Rail to 1st Panel}}$$

Example: (Using 44.6" wide module)

$$44.6" \times 15 = 669" + 16" = 685" - 744.1" = -59.1 \div -2 = 29.5"$$

29.5 Inches is the distance from the end of the Rail to the 1st Panel Edge Installed

Max Panel Width 48.6"

Authority Having Jurisdiction (AHJ) to provide max wind and snow load requirements for install location

Side Profile Ground Mount

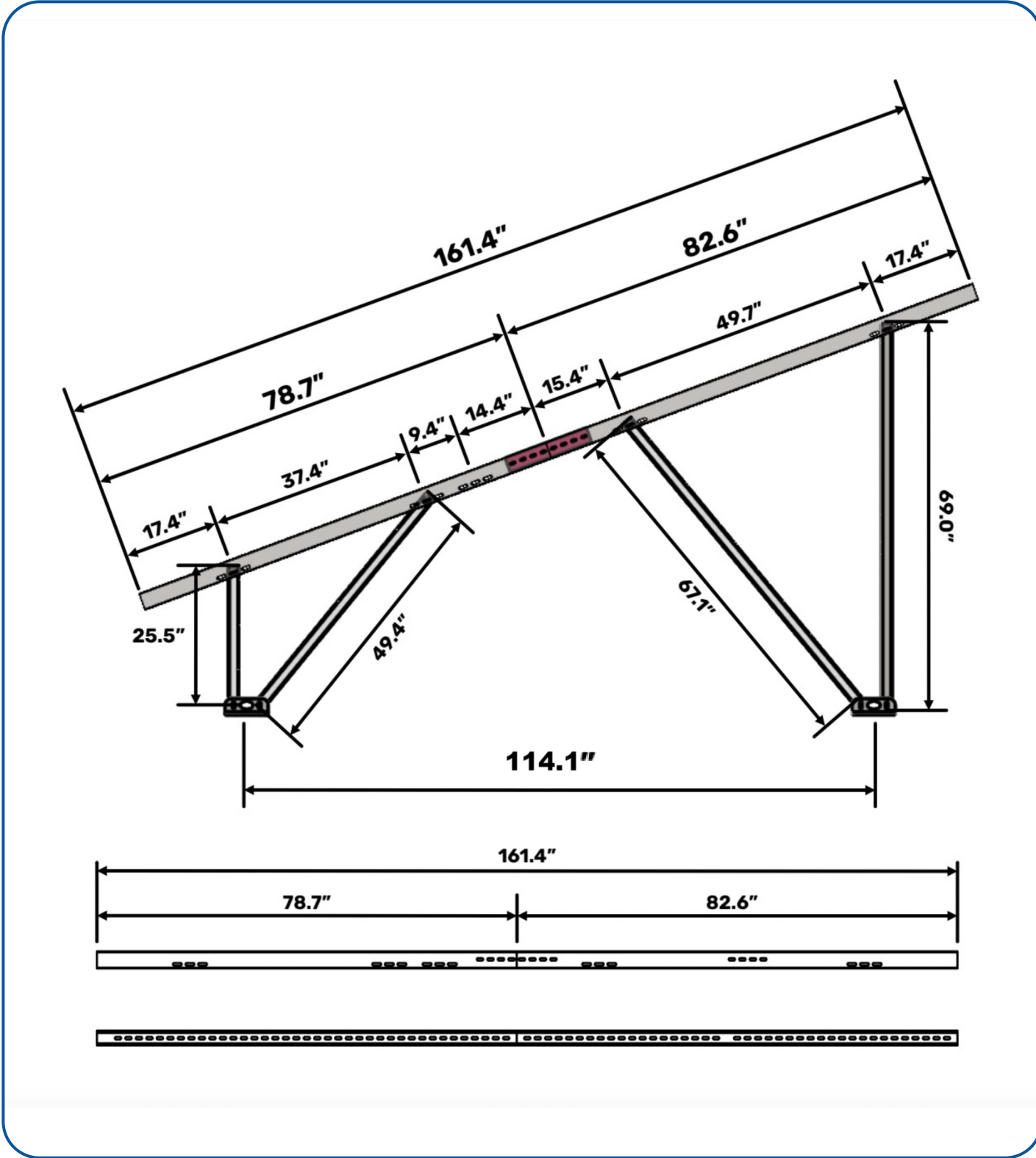

What is a Bolt Kit?

A **“Bolt Kit”** is a metric fastener set used for joining or securing components within our solar ground mount. The name describes the specific physical dimensions and intended application of the hardware. For example, we will examine a M10 30mm Bolt Kit as it is the most common within this installation manual.

Breakdown of the Specifications:

- **M10 (Diameter):**
The “M” stands for Metric, and “10” indicates a nominal outer diameter of 10 millimeters.
- **30mm (Length):**
This refers to the length of the bolt’s shaft. In standard hex bolts, this is measured from under the head to the very tip of the bolt
- **Kit (Components):**
Unlike buying a single bolt, a “kit” typically includes several matching pieces to complete a connection. Our Kit contains:

 - **The Bolt:** The threaded fastener itself.
 - **The Nut:** Usually a hex nut or flange nut to secure the bolt.
 - **Washers:** QTY 2 Flat washers (to distribute pressure).
 - **Lock Washer:** circular and split, to prevent loosening from vibration.

Within the install guide reference will be made to “Bolt Kits” the above description is indicative as to what is included in a CHIKOUSA Bolt Kit.

There are 2 different bolt Kit Sizes that come standard. For every CHIKOUSA U2V Ground Mount:

- M10*30mm Bolt Kits
- M10*80mm Bolt Kits

M10*30mm Bolt Kit (Sizing Example)

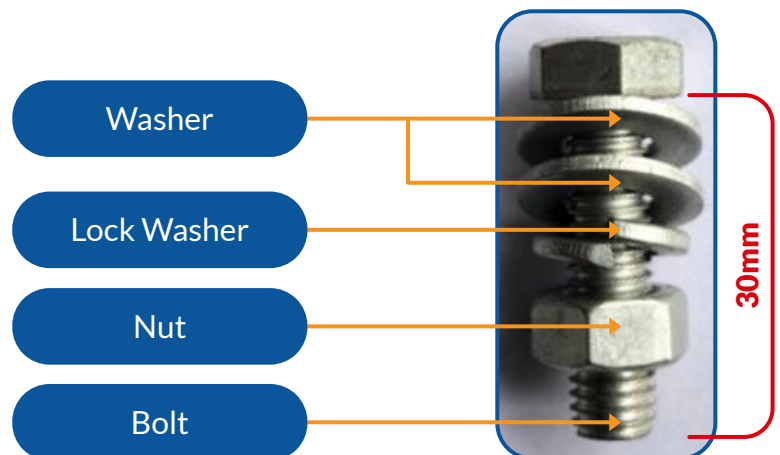



CHIKOUSA Ground Mount

10-Panel Base Model BOM

CHIKO GROUND MOUNT			10 PANEL	
IMAGES	BOM COUNT	LENGTH IN INCHES	DESCRIPTION	PART NUMBER
	12	82.7	U72 Rail (2100mm)	CK-UR72-T2.5-001-2100
	12	8	U72 Rail Splice	CK-0221RU72-3-200
	48	1.2	M10*30mm Bolt Kit For Rail Splice	CK-JGI-Q1030
	20		Mid clamp (30-40mm with grounding pin)	CK-777RU-K-(30-40)-50
	8		End clamp (30-42mm with ground pin)	CK-749RU-K-(30-42)-40
	4	78.7	Beam #1-(2000mm)	CK-ET-011-197-34-C26-1-U2V-2000mm
	4	82.7	Beam #2-(2100mm)	CK-ET-011-197-34-C26-1-U2V-2100mm
	4	16	Beam Splice	CK-ET-006-197-80-4003
	32	3.1	M10*80mm Bolt Kit For Beam Splice	CK-JH-1080-2
	4	25.6 and 49.4	Front V-Leg (Assembled)	C26-1-U2V-650/1255
	4	67.1 and 69.0	Rear V-Leg (Assembled)	CK-U2V-V-1705/1753
	16		M10*30mm Bolt Kit for Rail Attached to Beam	CK-JGW-Q1030-2
	16		M10*80MM Bolt Kit for V-Leg Attached to Beam	CK-HS-006-2
	4	78.7	Strengthen Pipe #1 (2000mm)	CK-ET-001-197-34-C26-4-2000
	4	39.4	Strengthen Pipe #2 (1000mm)	CK-ET-001-197-34-C26-4-1000
	8		Strengthening Pipe Adapter	CK-PL-084-3000
	8	1.2	M10*30mm Bolt Kit for Strengthening Pipe Adapter	
	16		M10 Nut & Washer For Strengthening Pipes	
	4		Orchid Bolt/Pipe M10 Connector	CK-IT-118
GRAND TOTAL M10*30MM BOLT KITS	72	1.2	For splices, bolts/hardware is packaged with the splices	
GRAND TOTAL M10*80MM BOLT KITS	48	3.1	For Beam Splices	

CHIKOUSA Ground Mount (CONTINUED) 10-Panel Base Model BOM



IMAGES	BOM COUNT	LENGTH IN INCHES	DESCRIPTION	PART NUMBER
	1		Grounding Lug	CK-592RU-1-20
	10		MLPE BOLT KITS for micro-inverter	CK-003RU-37

Mounting option: Ground Screw, Trident Mount, or Concrete Bolts (One Option Only)

Ground Screw:

IMAGES	BOM COUNT	LENGTH IN INCHES	DESCRIPTION	PART NUMBER
	8	65.0	Ground screw	CK-GST-N16-3.0T2(H)-800-1600
	8		Adjustable Flange	
	48	31.5	Bolt to Tighten Top Flange to Ground Screw Bottom M16*30mm	CK-JGH-Q1630
	16		M12*35mm Bolt Kit to attach bottom V-Legs to Ground Screw	CK-JGH-Q1235-2

Trident Mount:

IMAGES	BOM COUNT	LENGTH IN INCHES	DESCRIPTION	PART NUMBER
	8	10.2	Trident Mount	CK-NK-01
	8	7.8	Top Flange	CK-NK-SK-2-105
	24	47	Cylinder Piles	CK-402-T1200
Hardware	16	1.3	M12*35mm Bolt Kit (X2 for each top plate)	M12*35MM
	144	1	6.3*25mm Hexagonal Screws (4 Per Pile, 6 per Flange)	6.3*25MM

Concrete Bolts



	16		Concrete Bolts	CK-JEB-12150
-------------------------------------------------------------------------------------	----	--	----------------	--------------

CHIKOUSA Ground Mount

30-Panel Base Model BOM

CHIKO GROUND MOUNT			10 PANEL	
IMAGES	BOM COUNT	LENGTH IN INCHES	DESCRIPTION	PART NUMBER
	36	82.7	U72 Rail (2100mm)	CK-UR72-T2.5-001-2100
	36	8	U72 Rail Splice	CK-0221RU72-3-200
	144	1.2	M10*30mm Bolt Kit For Rail Splice	CK-JGI-Q1030
	60		Mid clamp (30-40mm with grounding pin)	CK-777RU-K-(30-40)-50
	8		End clamp (30-42mm with ground pin)	CK-749RU-K-(30-42)-40
	10	78.7	Beam #1-(2000mm)	CK-ET-011-197-34-C26-1-U2V-2000mm
	10	82.7	Beam #2-(2100mm)	CK-ET-011-197-34-C26-1-U2V-2100mm
	10	16	Beam Splice	CK-ET-006-197-80-4003
	10	3.1	M10*80mm Bolt Kit For Beam Splice	CK-JH-1080-2
	10	25.6 and 49.4	Front V-Leg (Assembled)	C26-1-U2V-650/1255
	10	67.1 and 69.0	Rear V-Leg (Assembled)	CK-U2V-V-1705/1753
	40		M10*30mm Bolt Kit for Rail Attached to Beam	CK-JGW-Q1030-2
	40		M10*80MM Bolt Kit for V-Leg Attached to Beam	CK-HS-006-2
	10	78.7	Strengthen Pipe #1 (2000mm)	CK-ET-001-197-34-C26-4-2000
	10	39.4	Strengthen Pipe #2 (1000mm)	CK-ET-001-197-34-C26-4-1000
	20		Strengthening Pipe Adapter	CK-PL-084-3000
	20	1.2	M10*30mm Bolt Kit for Strengthening Pipe Adapter	
	20		M10 Nut & Washer For Strengthening Pipes	
	10		Orchid Bolt/Pipe M10 Connector	CK-IT-118
GRAND TOTAL M10*30MM BOLT KITS	204	1.2	For splices, bolts/hardware is packaged with the splices	
GRAND TOTAL M10*80MM BOLT KITS	128	3.1	For Beam Splices	

CHIKOUSA Ground Mount (CONTINUED) 30-Panel Base Model BOM



IMAGES	BOM COUNT	LENGTH IN INCHES	DESCRIPTION	PART NUMBER
	1		Grounding Lug	CK-592RU-1-20
	30		MLPE BOLT KITS for micro-inverter	CK-003RU-37

Mounting option: Ground Screw, Trident Mount, or Concrete Bolts (One Option Only)

Ground Screw:

IMAGES	BOM COUNT	LENGTH IN INCHES	DESCRIPTION	PART NUMBER
	20	65.0	Ground screw	CK-GST-N16-3.0T2(H)-800-1600
	20		Adjustable Flange	
	120	31.5	Bolt to Tighten Top Flange to Ground Screw Bottom M16*30mm	CK-JGH-Q1630
	40		M12*35mm Bolt Kit to attach bottom V-Legs to Ground Screw	CK-JGH-Q1235-2

Trident Mount:

IMAGES	BOM COUNT	LENGTH IN INCHES	DESCRIPTION	PART NUMBER
	20	10.2	Trident Mount	CK-NK-01
	20	7.8	Top Flange	CK-NK-SK-2-105
	60	47	Cylinder Piles	CK-402-T1200
Hardware	40	1.3	M12*35mm Bolt Kit (X2 for each top plate)	M12*35MM
	360	1	6.3*25mm Hexagonal Screws (4 Per Pile, 6 per Flange)	6.3*25MM

Concrete Bolts



	40		Concrete Bolts	CK-JEB-12150
-------------------------------------------------------------------------------------	----	--	----------------	--------------

CHIKOUSA Ground Mount

10-Panel High-Strength Model BOM

CHIKO GROUND MOUNT			10 PANEL	
IMAGES	BOM COUNT	LENGTH IN INCHES	DESCRIPTION	PART NUMBER
	12	82.7	U72 Rail (2100mm)	CK-UR72-T2.5-001-2100
	12	8	U72 Rail Splice	CK-0221RU72-3-200
	48	1.2	M10*30mm Bolt Kit For Rail Splice	CK-JGI-Q1030
	20		Mid clamp (30-40mm with grounding pin)	CK-777RU-K-(30-40)-50
	8		End clamp (30-42mm with ground pin)	CK-749RU-K-(30-42)-40
	5	78.7	Beam #1-(2000mm)	CK-ET-011-197-34-C26-1-U2V-2000mm
	5	82.7	Beam #2-(2100mm)	CK-ET-011-197-34-C26-1-U2V-2100mm
	5	16	Beam Splice	CK-ET-006-197-80-4003
	40	3.1	M10*80mm Bolt Kit For Beam Splice	CK-JH-1080-2
	5	25.6 and 49.4	Front V-Leg (Assembled)	C26-1-U2V-650/1255
	5	67.1 and 69.0	Rear V-Leg (Assembled)	CK-U2V-V-1705/1753
	20		M10*30mm Bolt Kit for Rail Attached to Beam	CK-JGW-Q1030-2
	20		M10*80MM Bolt Kit for V-Leg Attached to Beam	CK-HS-006-2
	5	78.7	Strengthen Pipe #1 (2000mm)	CK-ET-001-197-34-C26-4-2000
	5	39.4	Strengthen Pipe #2 (1000mm)	CK-ET-001-197-34-C26-4-1000
	10		Strengthening Pipe Adapter	CK-PL-084-3000
	10	1.2	M10*30mm Bolt Kit for Strengthening Pipe Adapter	
	20		M10 Nut & Washer For Strengthening Pipes	
	5		Orchid Bolt/Pipe M10 Connector	CK-IT-118
GRAND TOTAL M10*30MM BOLT KITS	78	1.2	For splices, bolts/hardware is packaged with the splices	
GRAND TOTAL M10*80MM BOLT KITS	60	3.1	For Beam Splices	

CHIKOUSA Ground Mount (CONTINUED) 10-Panel High-Strength Model BOM



IMAGES	BOM COUNT	LENGTH IN INCHES	DESCRIPTION	PART NUMBER
	1		Grounding Lug	CK-592RU-1-20
	10		MLPE BOLT KITS for micro-inverter	CK-003RU-37

Mounting option: Ground Screw, Trident Mount, or Concrete Bolts (One Option Only)

Ground Screw:

IMAGES	BOM COUNT	LENGTH IN INCHES	DESCRIPTION	PART NUMBER
	10	65.0	Ground screw	CK-GST-N16-3.0T2(H)-800-1600
	10	31.5	Adjustable Flange	
	60		Bolt to Tighten Top Flange to Ground Screw Bottom M16*30mm	CK-JGH-Q1630
	20		M12*35mm Bolt Kit to attach bottom V-Legs to Ground Screw	CK-JGH-Q1235-2

Trident Mount:

IMAGES	BOM COUNT	LENGTH IN INCHES	DESCRIPTION	PART NUMBER
	10	10.2	Trident Mount	CK-NK-01
	10	7.8	Top Flange	CK-NK-SK-2-105
	30	47	Cylinder Piles	CK-402-T1200
Hardware	20	1.3	M12*35mm Bolt Kit (X2 for each top plate)	M12*35MM
	180	1	6.3*25mm Hexagonal Screws (4 Per Pile, 6 per Flange)	6.3*25MM

Concrete Bolts



	40		Concrete Bolts	CK-JEB-12150
-------------------------------------------------------------------------------------	----	--	----------------	--------------

CHIKOUSA Ground Mount

30-Panel High-Strength Model BOM

CHIKO GROUND MOUNT			10 PANEL	
IMAGES	BOM COUNT	LENGTH IN INCHES	DESCRIPTION	PART NUMBER
	36	82.7	U72 Rail (2100mm)	CK-UR72-T2.5-001-2100
	36	8	U72 Rail Splice	CK-0221RU72-3-200
	144	1.2	M10*30mm Bolt Kit For Rail Splice	CK-JGI-Q1030
	60		Mid clamp (30-40mm with grounding pin)	CK-777RU-K-(30-40)-50
	8		End clamp (30-42mm with ground pin)	CK-749RU-K-(30-42)-40
	12	78.7	Beam #1-(2000mm)	CK-ET-011-197-34-C26-1-U2V-2000mm
	12	82.7	Beam #2-(2100mm)	CK-ET-011-197-34-C26-1-U2V-2100mm
	12	16	Beam Splice	CK-ET-006-197-80-4003
	96	3.1	M10*80mm Bolt Kit For Beam Splice	CK-JH-1080-2
	12	25.6 and 49.4	Front V-Leg (Assembled)	C26-1-U2V-650/1255
	12	67.1 and 69.0	Rear V-Leg (Assembled)	CK-U2V-V-1705/1753
	48		M10*30mm Bolt Kit for Rail Attached to Beam	CK-JGW-Q1030-2
	48		M10*80MM Bolt Kit for V-Leg Attached to Beam	CK-HS-006-2
	12	78.7	Strengthen Pipe #1 (2000mm)	CK-ET-001-197-34-C26-4-2000
	12	39.4	Strengthen Pipe #2 (1000mm)	CK-ET-001-197-34-C26-4-1000
	24		Strengthening Pipe Adapter	CK-PL-084-3000
	24	1.2	M10*30mm Bolt Kit for Strengthening Pipe Adapter	
	24		M10 Nut & Washer For Strengthening Pipes	
	12		Orchid Bolt/Pipe M10 Connector	CK-IT-118
GRAND TOTAL M10*30MM BOLT KITS	216	1.2	For splices, bolts/hardware is packaged with the splices	
GRAND TOTAL M10*80MM BOLT KITS	144	3.1	For Beam Splices	

CHIKOUSA Ground Mount (CONTINUED) 30-Panel High Strength Model BOM



IMAGES	BOM COUNT	LENGTH IN INCHES	DESCRIPTION	PART NUMBER
	1		Grounding Lug	CK-592RU-1-20
	30		MLPE BOLT KITS for micro-inverter	CK-003RU-37

Mounting option: Ground Screw, Trident Mount, or Concrete Bolts (One Option Only)

Ground Screw:

IMAGES	BOM COUNT	LENGTH IN INCHES	DESCRIPTION	PART NUMBER
	24	65.0	Ground screw	CK-GST-N16-3.0T2(H)-800-1600
	24		Adjustable Flange	
	124	31.5	Bolt to Tighten Top Flange to Ground Screw Bottom M16*30mm	CK-JGH-Q1630
	48		M12*35mm Bolt Kit to attach bottom V-Legs to Ground Screw	CK-JGH-Q1235-2

Trident Mount:

IMAGES	BOM COUNT	LENGTH IN INCHES	DESCRIPTION	PART NUMBER
	24	10.2	Trident Mount	CK-NK-01
	24	7.8	Top Flange	CK-NK-SK-2-105
	72	47	Cylinder Piles	CK-402-T1200
Hardware	48	1.3	M12*35mm Bolt Kit (X2 for each top plate)	M12*35MM
	432	1	6.3*25mm Hexagonal Screws (4 Per Pile, 6 per Flange)	6.3*25MM

Concrete Bolts

	48		Concrete Bolts	CK-JEB-12150
-------------------------------------------------------------------------------------	----	--	----------------	--------------

WORLDLEADING

M A N U F A C T U R E

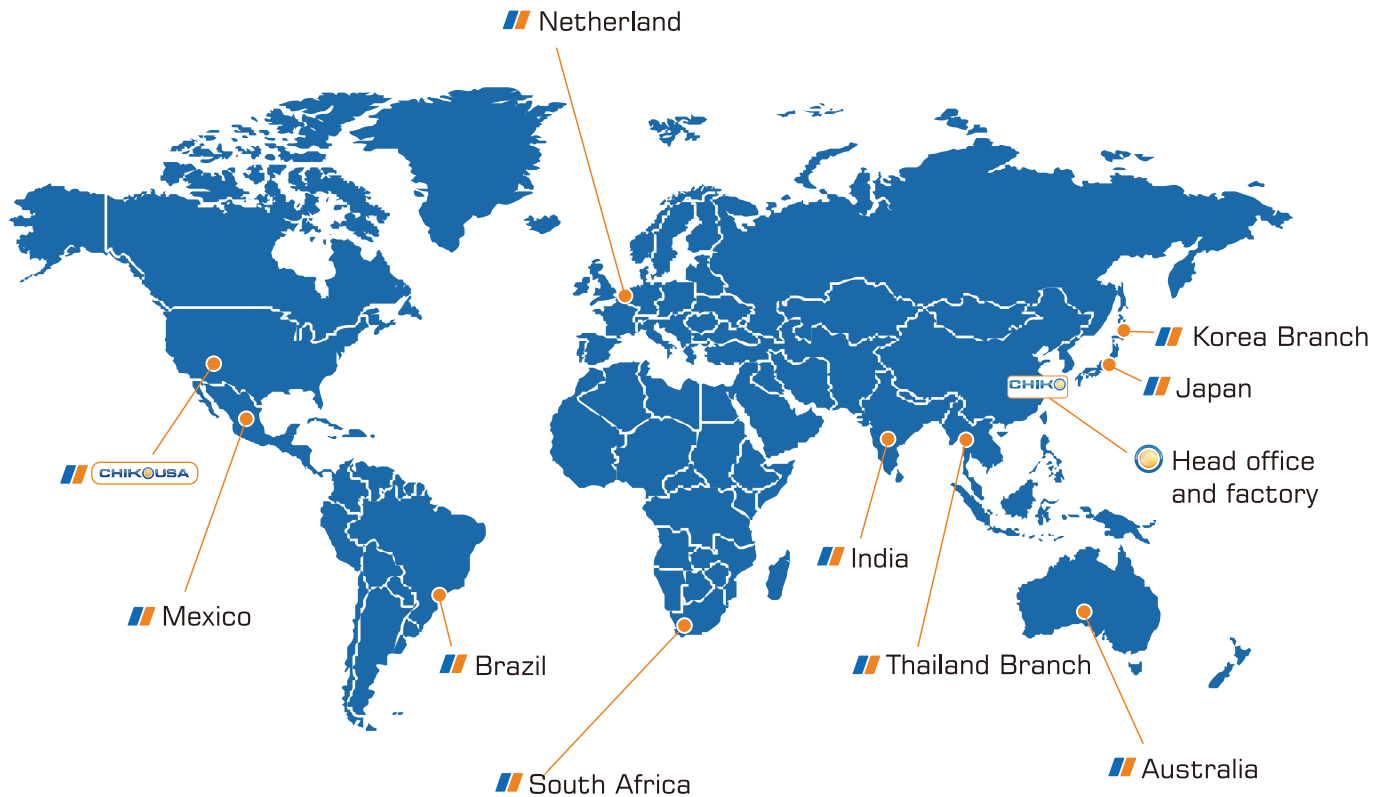

CHIKOUSA
RACKING MADE SIMPLE

Tel : 1-800-948-5390

Email : info@chikousa.com

www.chikousa.com



16413 North 91st Street
STE C-115
Scottsdale, AZ 85260



10-PANEL BASE

Large Format Size Module
 Max Length 96"
 Max Width 48"

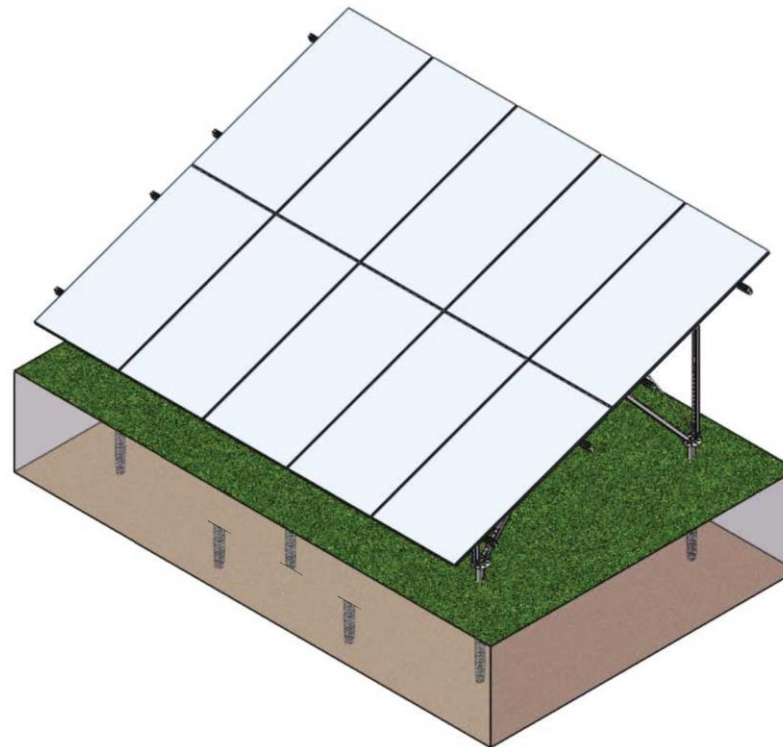
**CHIKOUSA U2V GROUND MOUNT
 20 DEGREE TILT ANGLE
 PORTRAIT MODULE ORIENTATION
 10 MODULES**



Illustrations are intended for general reference and may not reflect the exact configuration of your design

1	Mark	Modifivation	Modify by	Doc No.	Data	Des	J. Burton	240917	 U2V 2x5 20° View:  Rate Page 1
						Drw			
						Check			
						Craft			
						App			

A

B

C



D

10-PANEL BASE

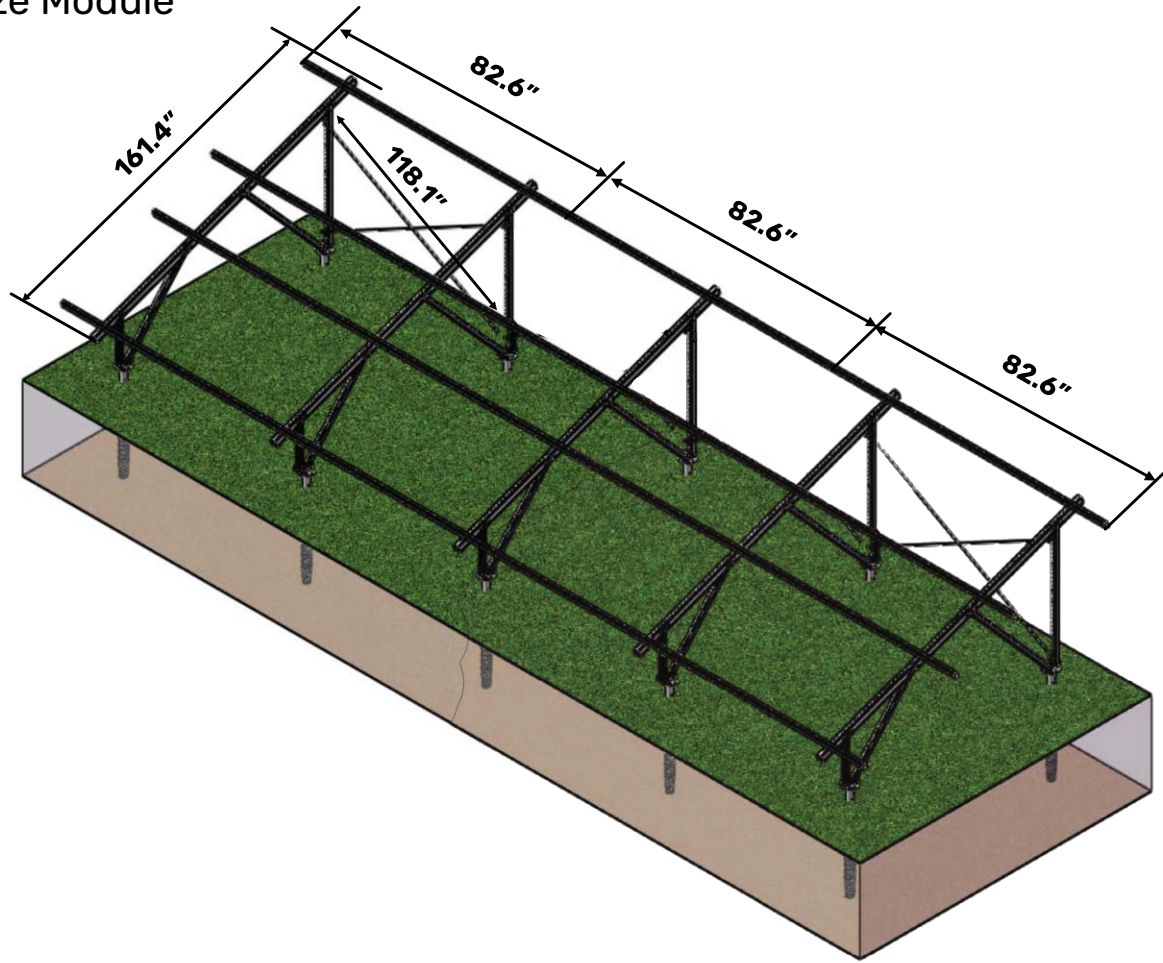
Large Format Size Module
 Max Length 96"
 Max Width 48"



Illustrations are intended for general reference and may not reflect the exact configuration of your design

1	Mark	Modifivation	Modify by	Doc No.	Data	Des	J. Burton	231109	 U2V 2x12-750 20° View:   Rate Page 2
						Drw			
						Check			
						Craft			
						App			

A

B

C

D



10-PANEL BASE

Large Format Size Module
 Max Length 96"
 Max Width 48"

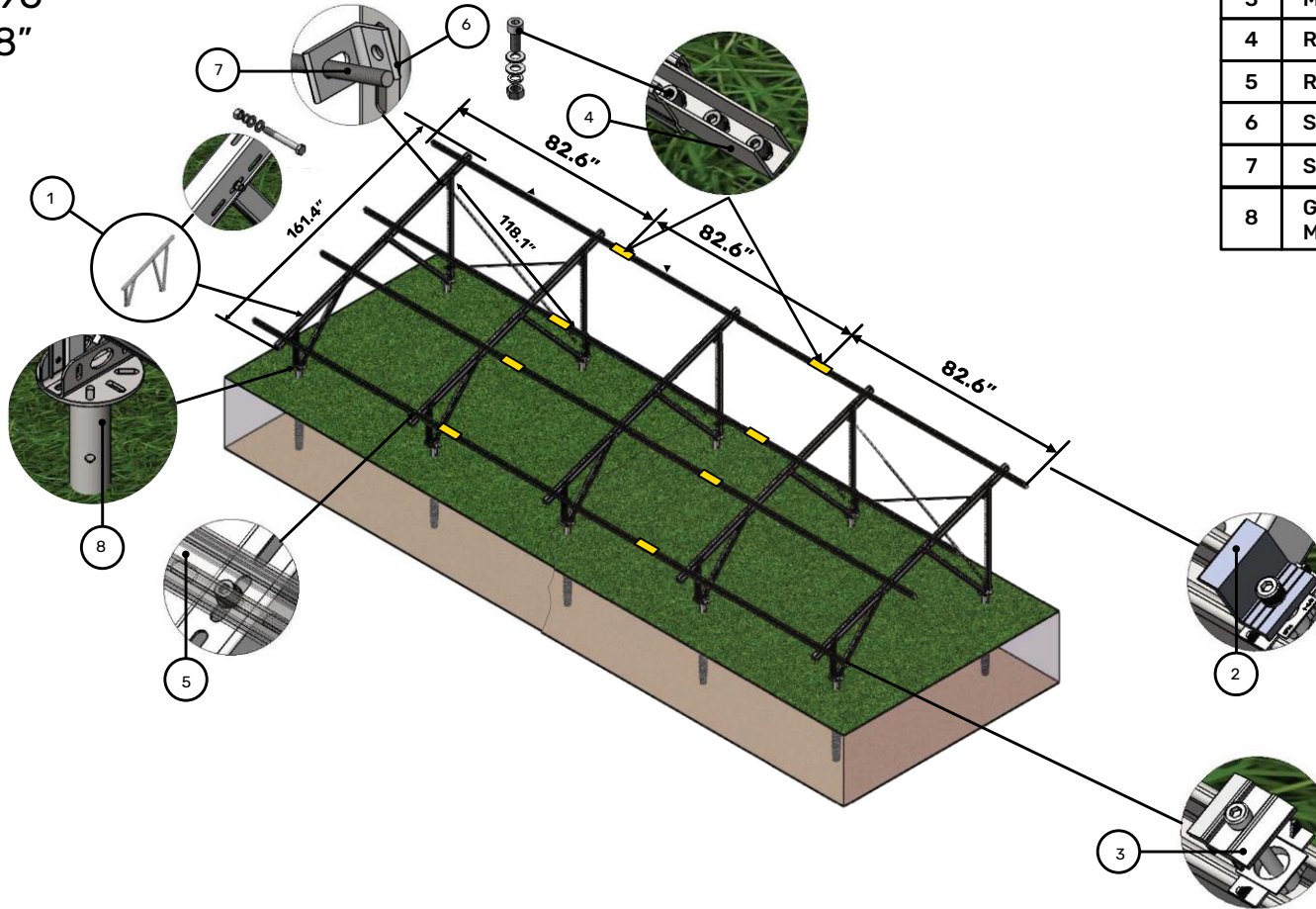
No	Description
1	Front & Rear V-Legs
2	End Clamp
3	Mid Clamp
4	Rail Splice Kit
5	Rail-4150
6	Strengthen Fix Kit
7	Strengthen Pipe
8	Ground Screw, Trident Mount, or Anchor Bolt



Illustrations are intended for general reference and may not reflect the exact configuration of your design

1	Mark	Modifivation	Modify by	Doc No.	Data	Des	J. Burton	240917	 U2V 2x5 20°
						Drw			
						Check			
						Craft			
						App			
	View: 						Rate		Page 3

A

B

C

D

10-PANEL BASE

Large Format Size Module
 Max Length 96"
 Max Width 48"

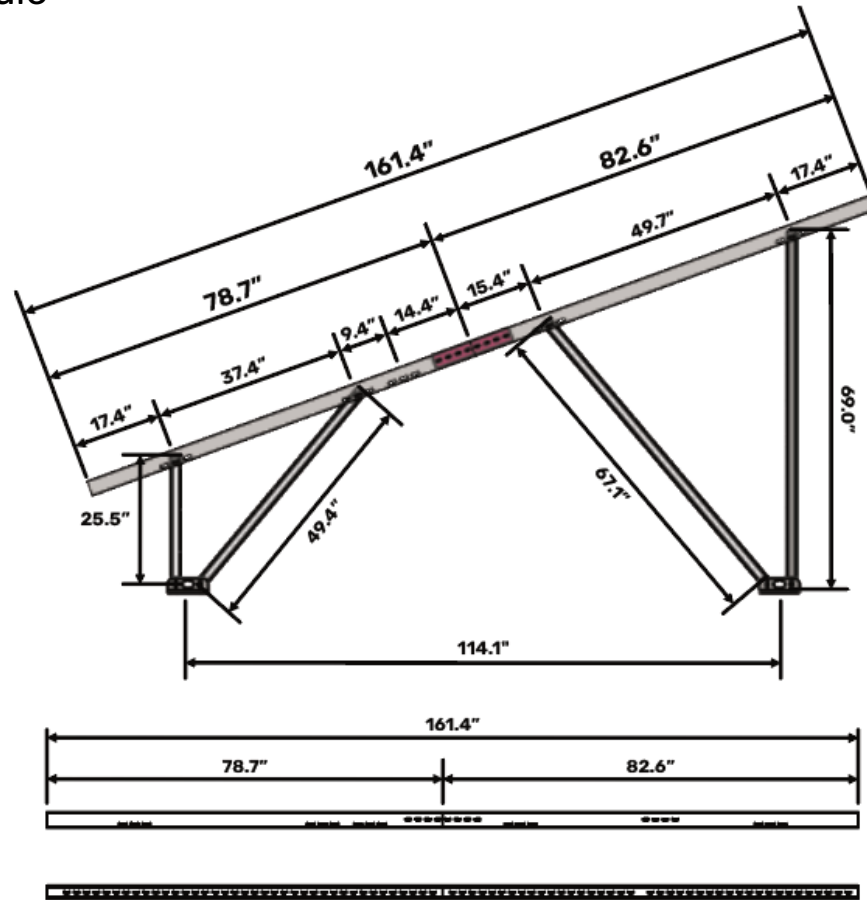

Illustrations are intended for general reference and may not reflect the exact configuration of your design

Mark	Modifivation	Modify by	Doc No.	Data	Des			View:		Rate	Page 4
					Drw						
					Check						
					Craft						
					App						

CHIKOUSA

10-PANEL BASE

Large Format Size Module
 Max Length 96"
 Max Width 48"

Attachment Distance

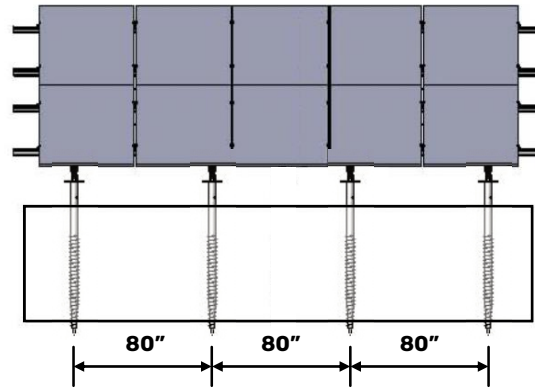

Rail Length

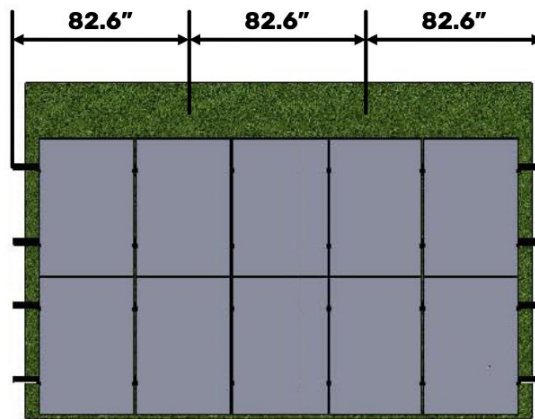

Illustrations are intended for general reference and may not reflect the exact configuration of your design

Mark	Modifivation	Modify by	Doc No.	Data	Des	J. Burton	240917		
					Drw				
					Check				
					Craft				
					App				
View:								Rate	Page 5

A

B

C

D

10-PANEL BASE

Large Format Size Module
 Max Length 96"
 Max Width 48"

Foundation/Attachment Layout

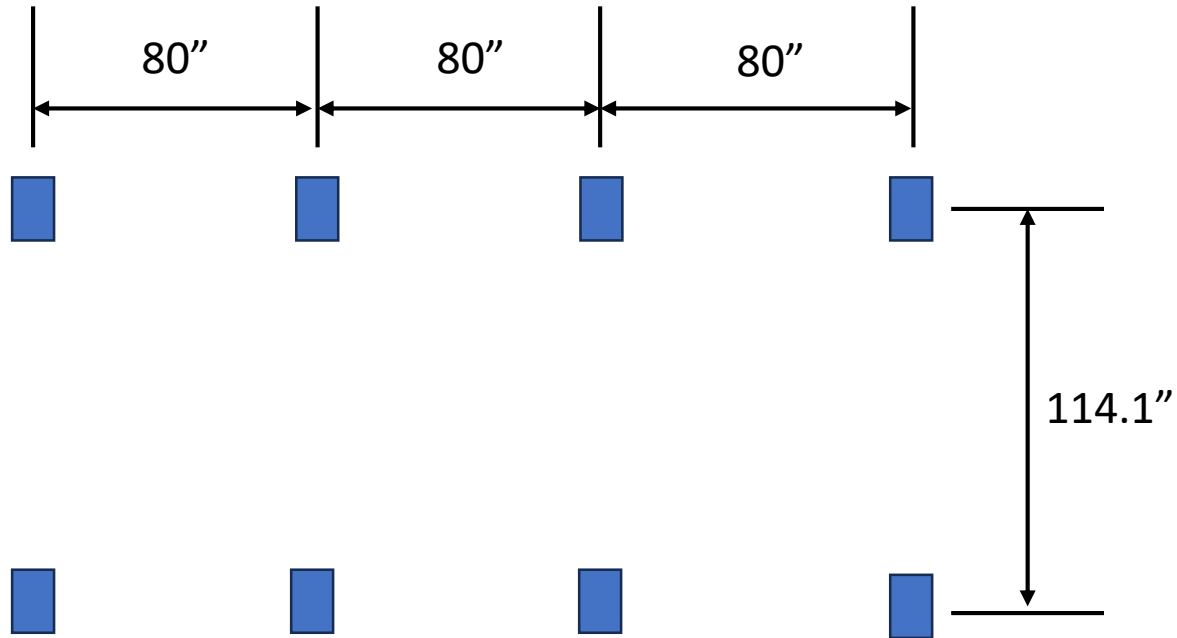

Ground Screw, Trident Mount, or Anchor Bolt

Illustrations are intended for general reference and may not reflect the exact configuration of your design

1	Mark	Modifivation	Modify by	Doc No.	Data	Des	J. Burton	240917		
						Drw				
						Check				
						Craft				
						App				
	View:							Rate		Page 6

A

B

C

D

10-PANEL HIGH-STRENGTH

Large Format Size Module
 Max Length 96"
 Max Width 48"

**CHIKOUSA U2V GROUND MOUNT
 20 DEGREE TILT ANGLE
 PORTRAIT MODULE ORIENTATION
 10 MODULES**

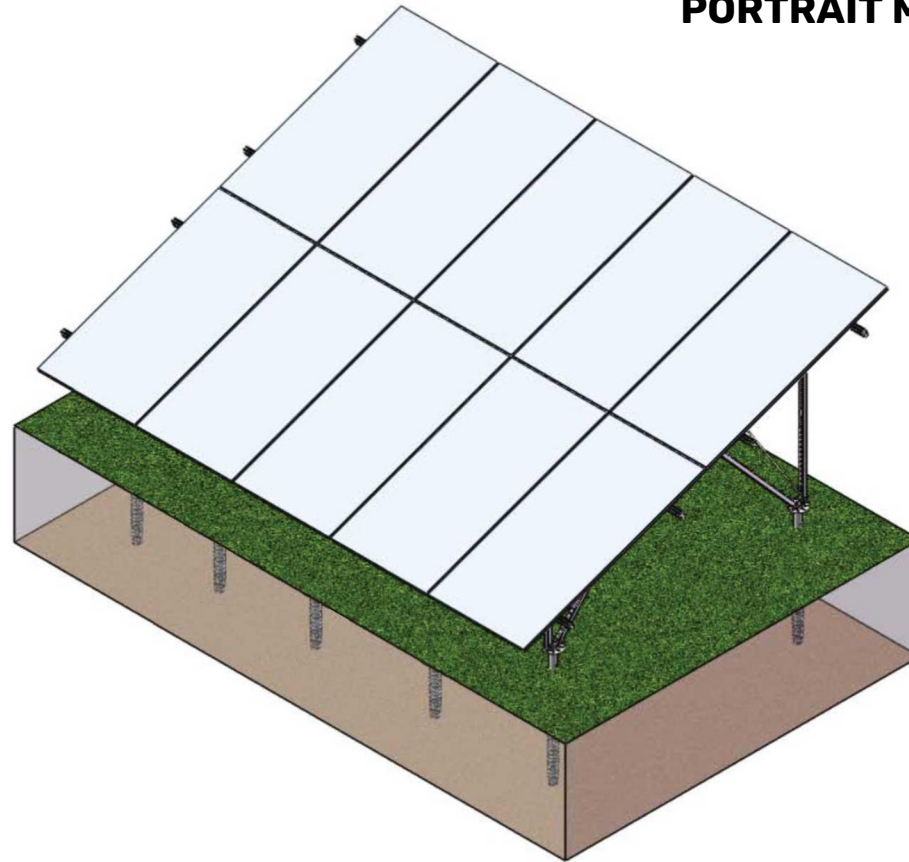

Illustrations are intended for general reference and may not reflect the exact configuration of your design

1	Mark	Modifivation	Modify by	Doc No.	Data	Des	J. Burton	240917	CHIKOUSA	U2V 2x5 20°	View:	Rate	Page 1
						Drw							
						Check							
						Craft							
						App							

A

B

C

D

10-PANEL HIGH-STRENGTH

Large Format Size Module
 Max Length 96"
 Max Width 48"

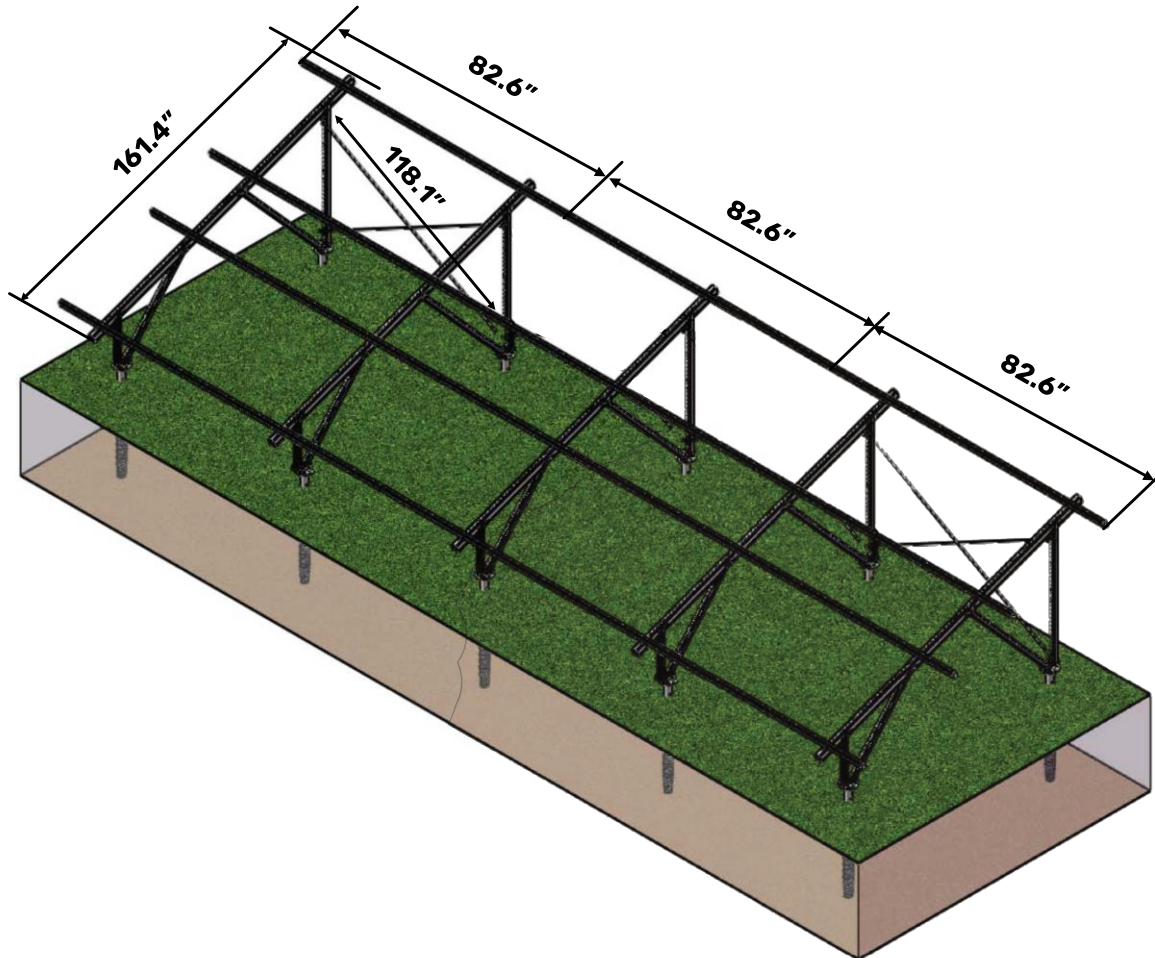

Illustrations are intended for general reference and may not reflect the exact configuration of your design

Mark	Modifivation	Modify by	Doc No.	Data	Des	J. Burton	231109	CHIROUSA U2V 2x12-750 20° View: Rate <input type="text"/> Page 2
					Drw			
					Check			
					Craft			
					App			

A

B

C

D



10-PANEL HIGH-STRENGTH

Large Format Size Module
 Max Length 96"
 Max Width 48"

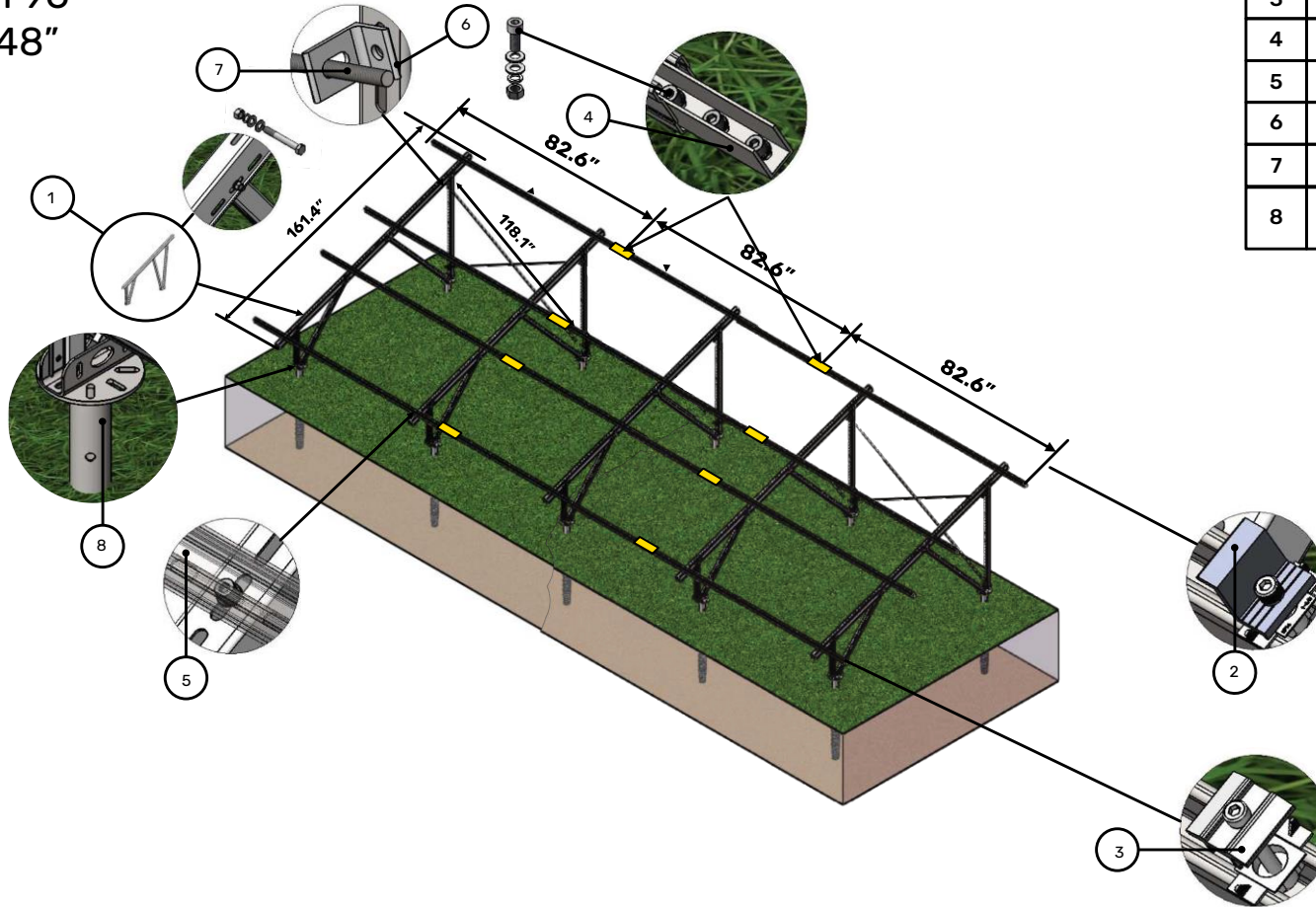
No	Description
1	Support Rack
2	End Clamp
3	Mid Clamp
4	Rail Splice Kit
5	Rail-4150
6	Strengthen Fix Kit
7	Strengthen Pipe
8	Ground Screw, Trident Mount, or Anchor Bolt



Illustrations are intended for general reference and may not reflect the exact configuration of your design

Mark	Modifivation	Modify by	Doc No.	Data	Des	J. Burton	240917	 U2V 2x5 20° View:  Rate Page 3			
					Drw						
					Check						
					Craft						
					App						

A

B

C



D

10-PANEL HIGH-STRENGTH

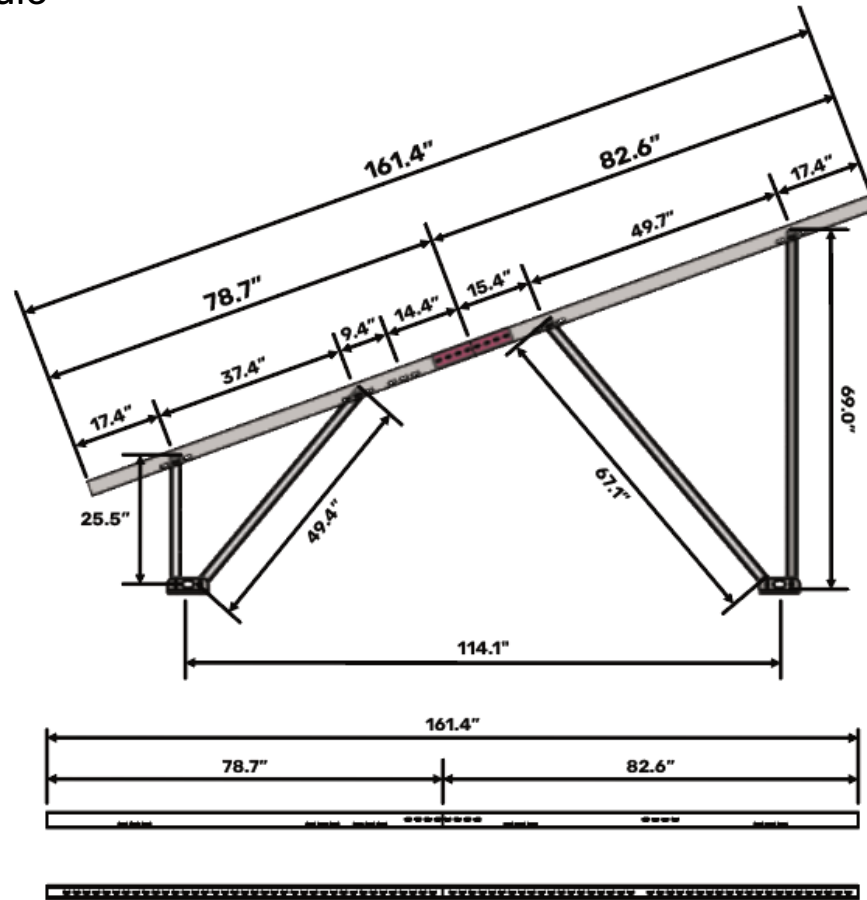
Large Format Size Module
 Max Length 96"
 Max Width 48"



Illustrations are intended for general reference and may not reflect the exact configuration of your design

Mark	Modifivation	Modify by	Doc No.	Data	Des							
					Drw							
					Check							
					Craft							
					App							
							View: 	Rate		Page 4		

10-PANEL HIGH-STRENGTH

Large Format Size Module
 Max Length 96"
 Max Width 48"

Attachment Distance

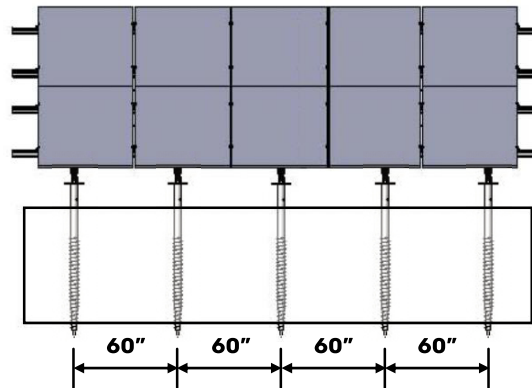

Rail Length

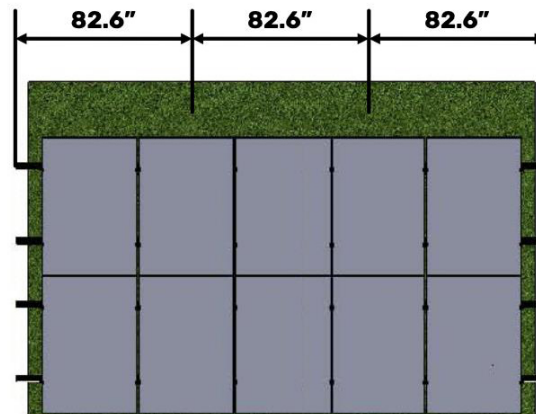

Illustrations are intended for general reference and may not reflect the exact configuration of your design

Mark	Modifivation	Modify by	Doc No.	Data	Des	J. Burton	240917	CHIROUSA
					Drw			
					Check			
					Craft			
					App			
								View:
								Rate
								Page 5

A

B

C

D

10-PANEL HIGH-STRENGTH

Large Format Size Module
 Max Length 96"
 Max Width 48"

Foundation/Attachment Layout

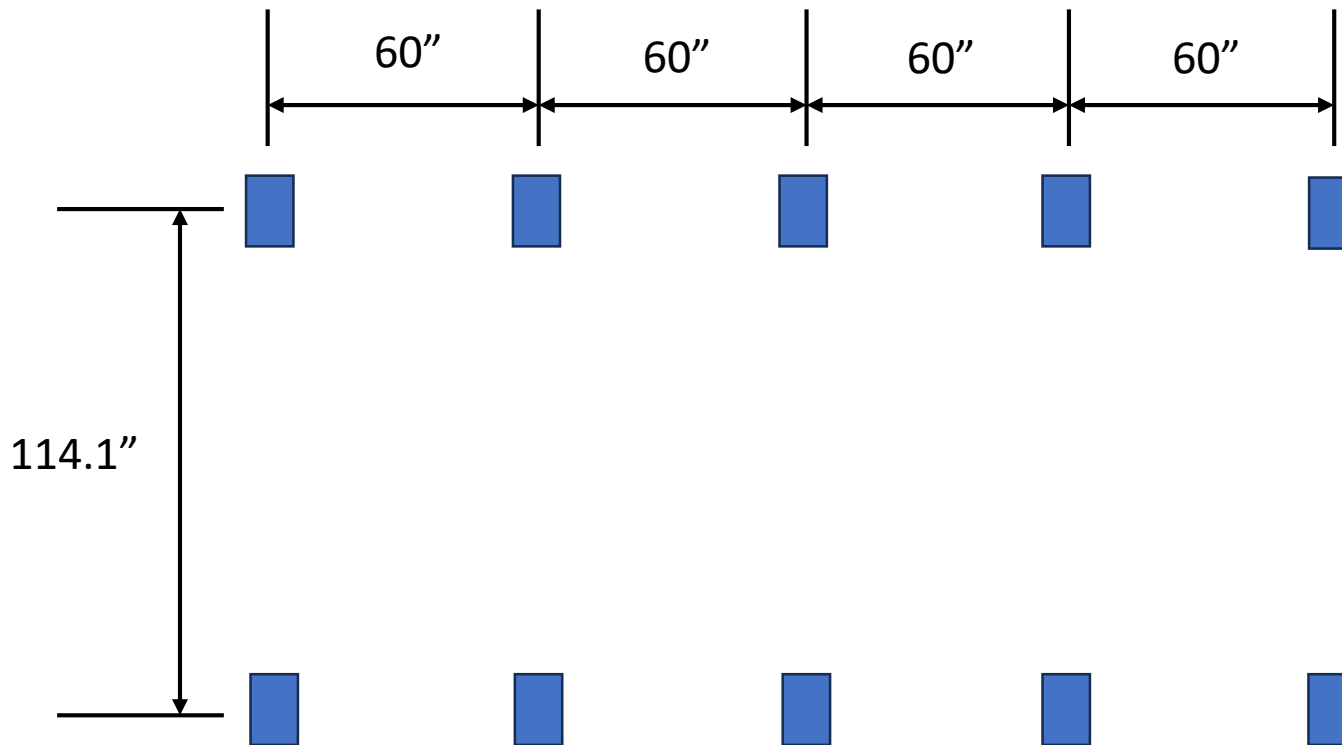

Illustrations are intended for general reference and may not reflect the exact configuration of your design

Mark	Modifivation	Modify by	Doc No.	Data	Des	J. Burton	240917			
					Drw					
					Check					
					Craft					
					App					
View:								Rate		Page 6

A

B

C

D



30-PANEL BASE

Large Format Size Module
 Max Length 96"
 Max Width 45"

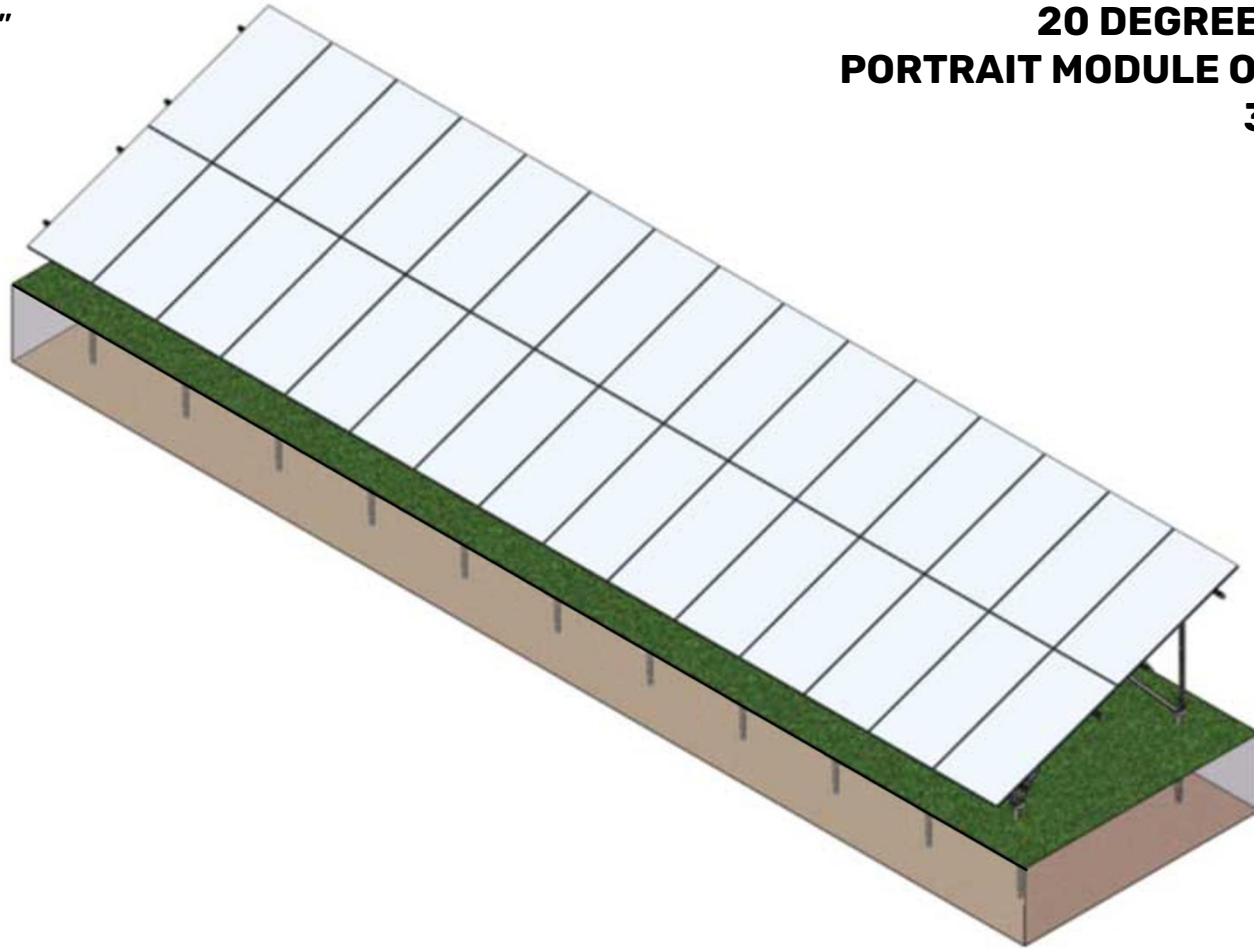
**CHIKOUSA U2V GROUND MOUNT
 20 DEGREE TILT ANGLE
 PORTRAIT MODULE ORIENTATION
 30 MODULES**



Illustrations are intended for general reference and may not reflect the exact configuration of your design

1	Mark	Modifivation	Modify by	Doc No.	Data	Des	J. Burton	240918	 U2V 2x15 20° View:  Rate Page 1
						Drw			
						Check			
						Craft			
						App			

A

B

C



D

30-PANEL BASE

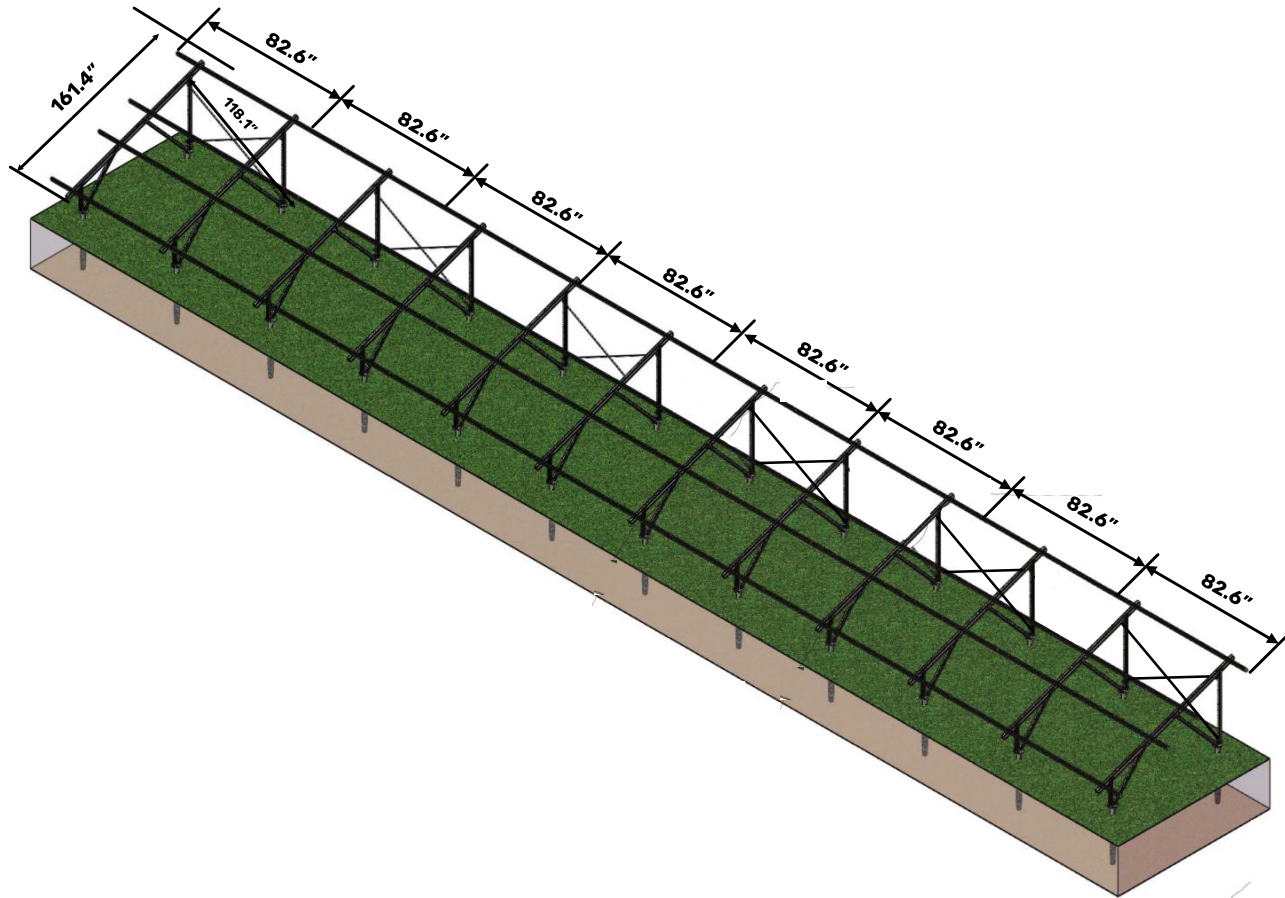
Large Size Module
 Max Length 96"
 Max Width 48"



Illustrations are intended for general reference and may not reflect the exact configuration of your design

1	Mark	Modifivation	Modify by	Doc No.	Data	Des	J. Burton	240918	 U2V 2x15 20° View:  Rate Page 2
						Drw			
						Check			
						Craft			
						App			

A

B

C

D

30-PANEL BASE

Large Format Size Module
 Max Length 96"
 Max Width 48"

No	Description
1	Front & Rear V-Legs
2	End Clamp
3	Mid Clamp
4	Rail Splice Kit
5	Rail-4150
6	Strengthen Fix Kit
7	Strengthen Pipe
8	Ground Screw, Trident Mount, or Anchor Bolt

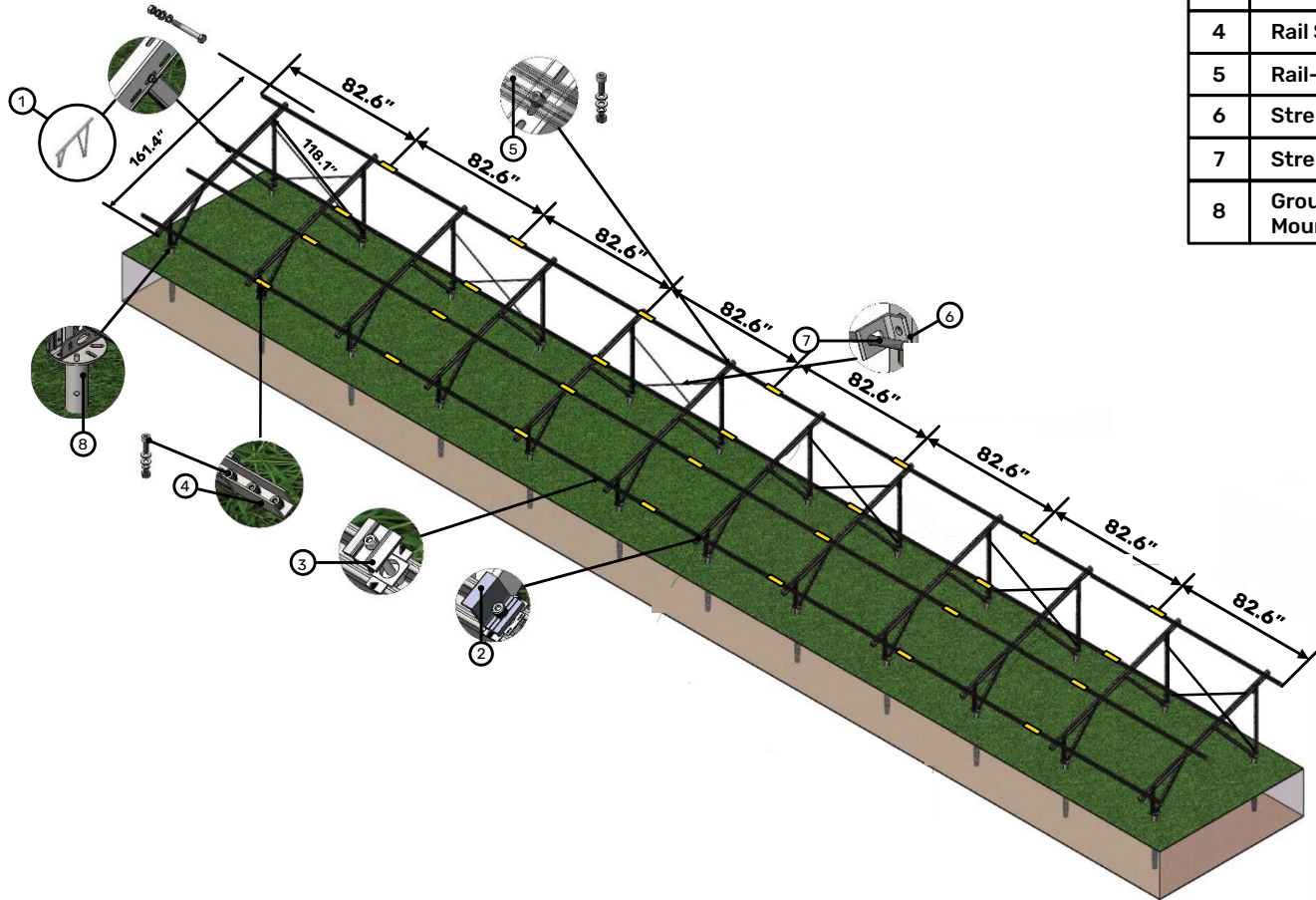

Illustrations are intended for general reference and may not reflect the exact configuration of your design

Mark	Modifivation	Modify by	Doc No.	Data	Des	J. Burton	240918
					Drw		
					Check		
					Craft		
					App		

CHIKOUSA

U2V

2x15 20°

View:

Rate

Page 3

A

B

C

D

30-PANEL BASE

Large Format Size Module
 Max Length 96"
 Max Width 48"

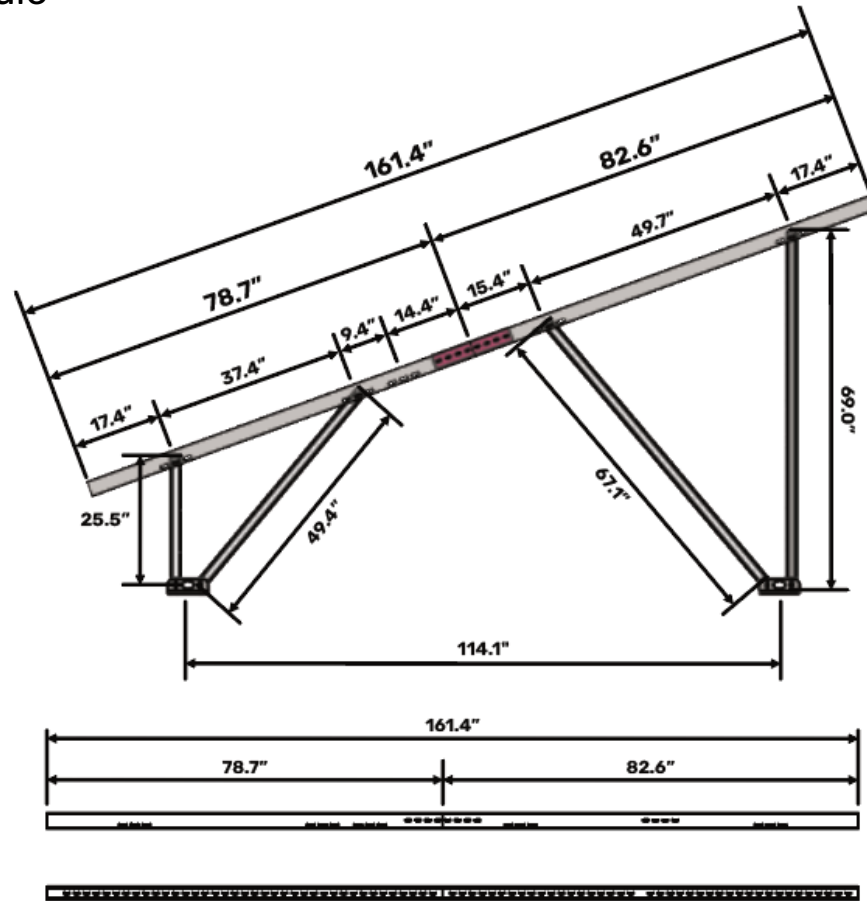

Illustrations are intended for general reference and may not reflect the exact configuration of your design

Mark	Modifivation	Modify by	Doc No.	Data	Des			View:		Rate	Page 4
					Drw						
					Check						
					Craft						
					App						

CHIKOUSA

A

B

C

D

30-PANEL BASE

Large Format Size Module

Max Length 96"

Max Width 48"

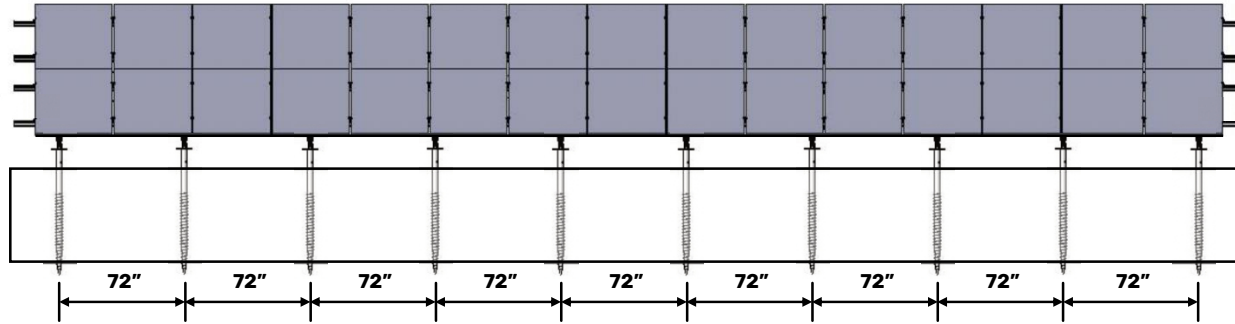

Attachment Distance

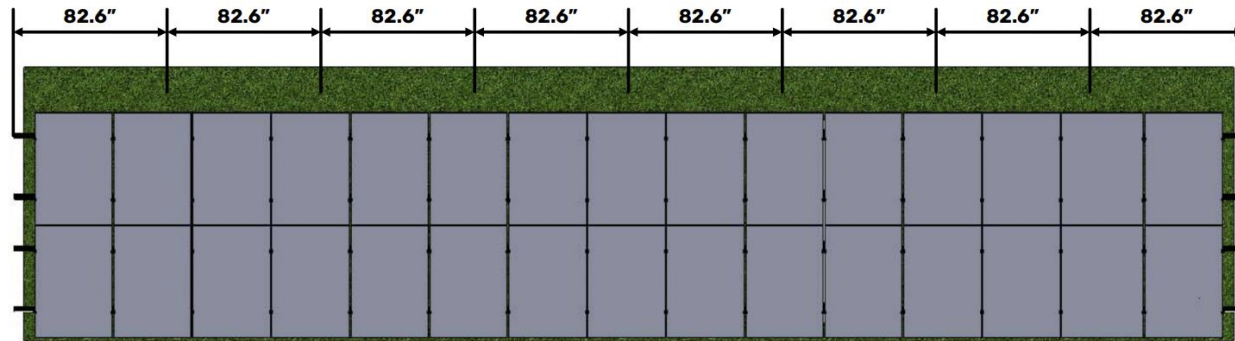

Rail Length



Illustrations are intended for general reference and may not reflect the exact configuration of your design

Mark	Modifivation	Modify by	Doc No.	Data	Des	J. Burton	240918		
					Drw				
					Check				
					Craft				
					App				
View: 								Rate	Page 5

A

B

C

D

30-PANEL BASE

Large Format Size Module
 Max Length 96"
 Max Width 48"

Foundation/Attachment Layout

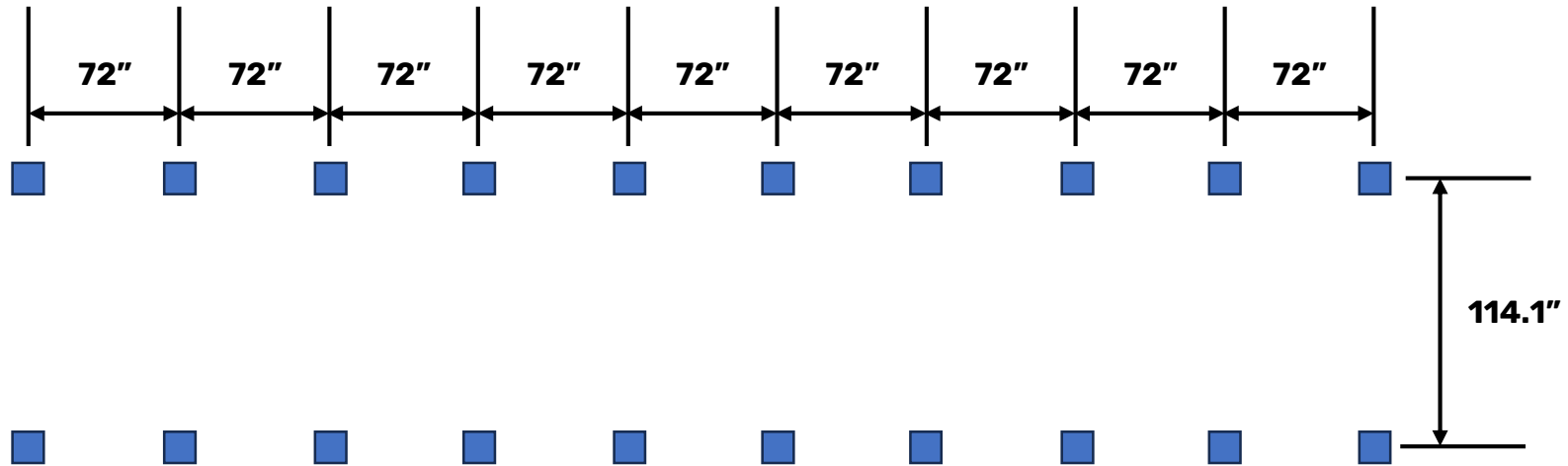

Illustrations are intended for general reference and may not reflect the exact configuration of your design

Mark	Modifivation	Modify by	Doc No.	Data	Des	J. Burton	240918	CHIROUSA						
					Drw						U2V			
					Check						2x15 20°			
					Craft						View:	Rate		Page 6
					App									

A

B

C

D

30-PANEL HIGH-STRENGTH

Large Format Size Module
 Max Length 96"
 Max Width 48"

CHIKOUSA U2V GROUND MOUNT
20 DEGREE TILT ANGLE
PORTRAIT MODULE ORIENTATION
30 MODULES

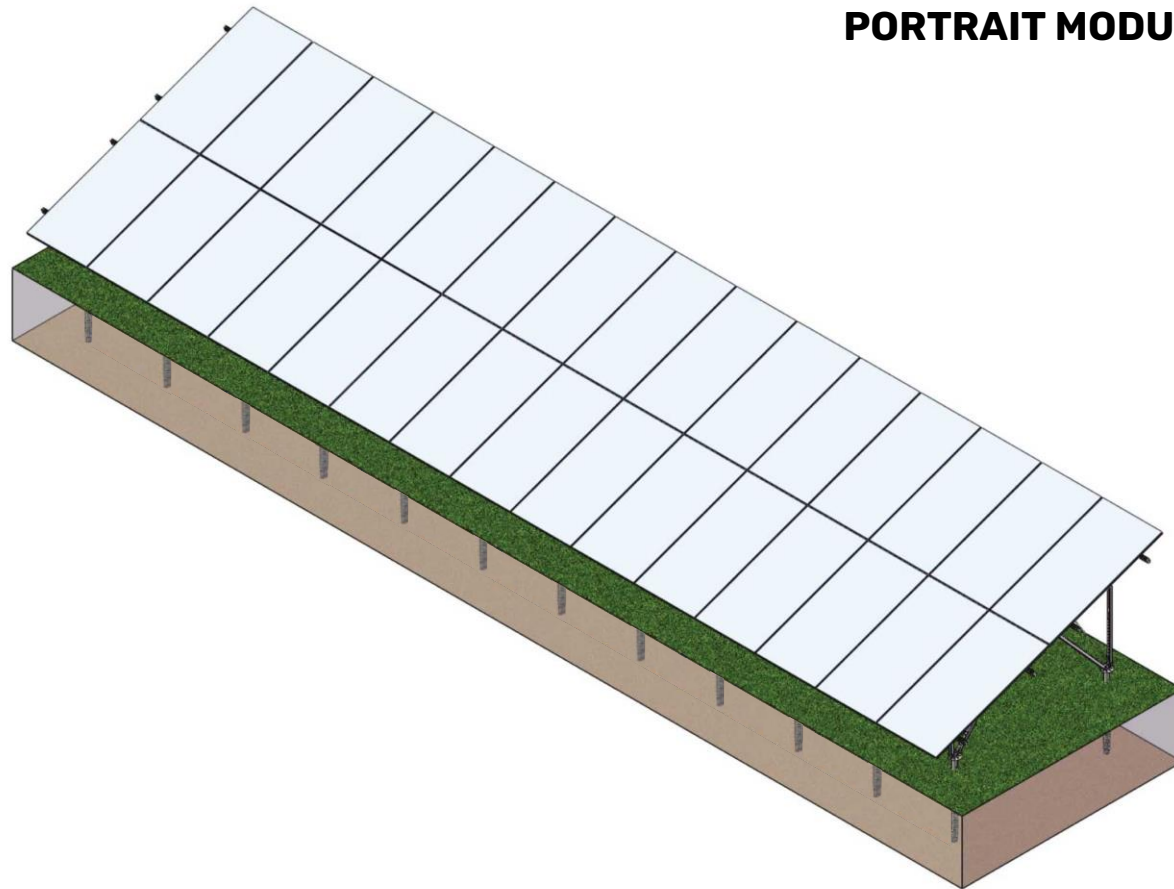

Illustrations are intended for general reference and may not reflect the exact configuration of your design

Mark	Modifivation	Modify by	Doc No.	Data	Des	J. Burton	240918	CHIKOUSA			
					Drw				U2V		
					Check				2x15 20°		
					Craft				View:	Rate	Page 1
					App						

A

B

C

D

30-PANEL HIGH-STRENGTH

Large Format Size Module

Max Length 96"

Max Width 48"

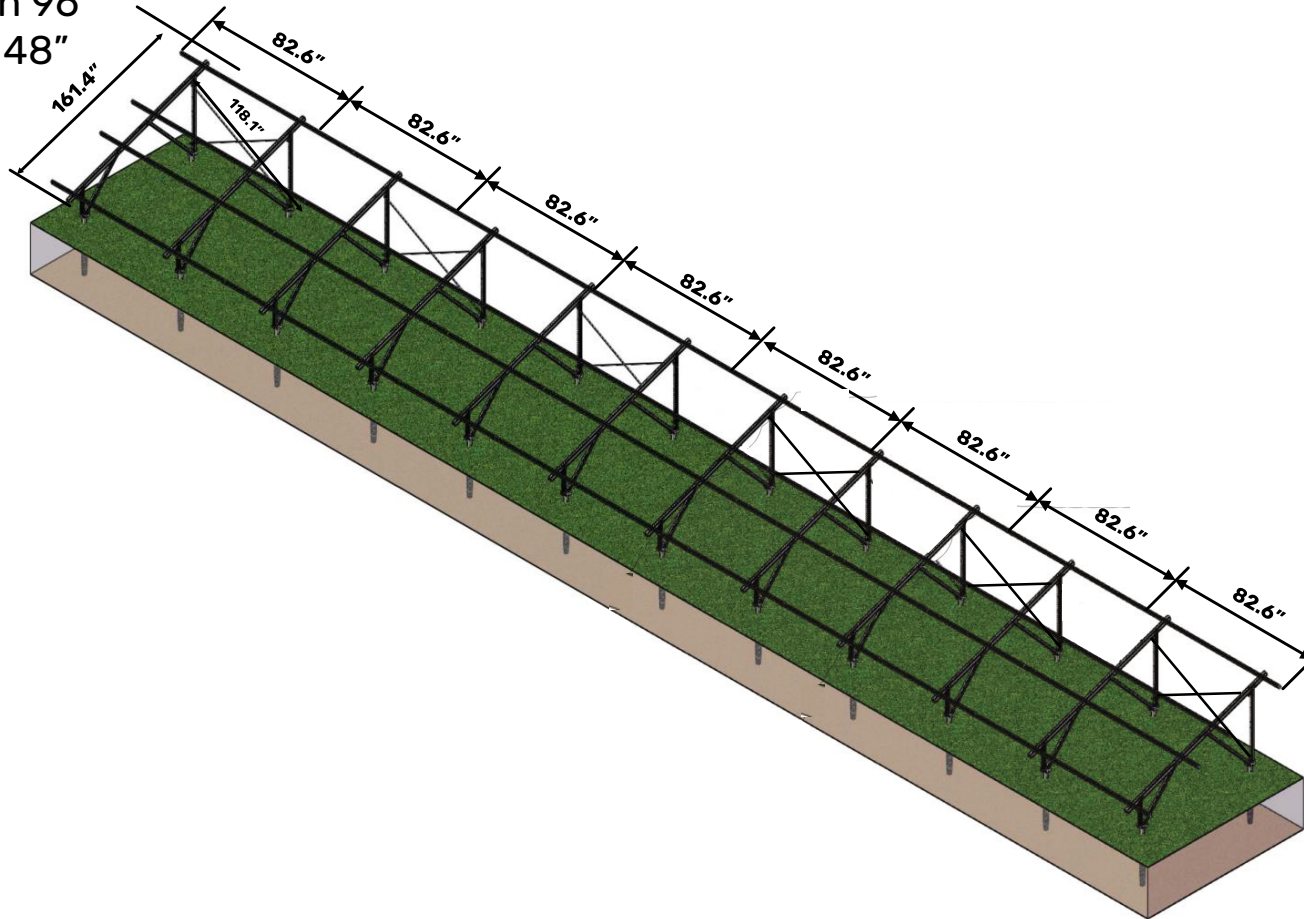

Illustrations are intended for general reference and may not reflect the exact configuration of your design

Mark	Modifivation	Modify by	Doc No.	Data	Des	J. Burton	240918	CHIROUSA	
					Drw				
					Check				
					Craft				
					App				
								U2V	
								2x15 20°	
View:								Rate	Page 2

A

B

C

D

30-PANEL HIGH-STRENGTH

Large Format Size Module
 Max Length 96"
 Max Width 48"

No	Description
1	Support Rack
2	End Clamp
3	Mid Clamp
4	Rail Splice Kit
5	Rail-4150
6	Strengthen Fix Kit
7	Strengthen Pipe
8	Ground Screw, Trident Mount, or Anchor Bolt

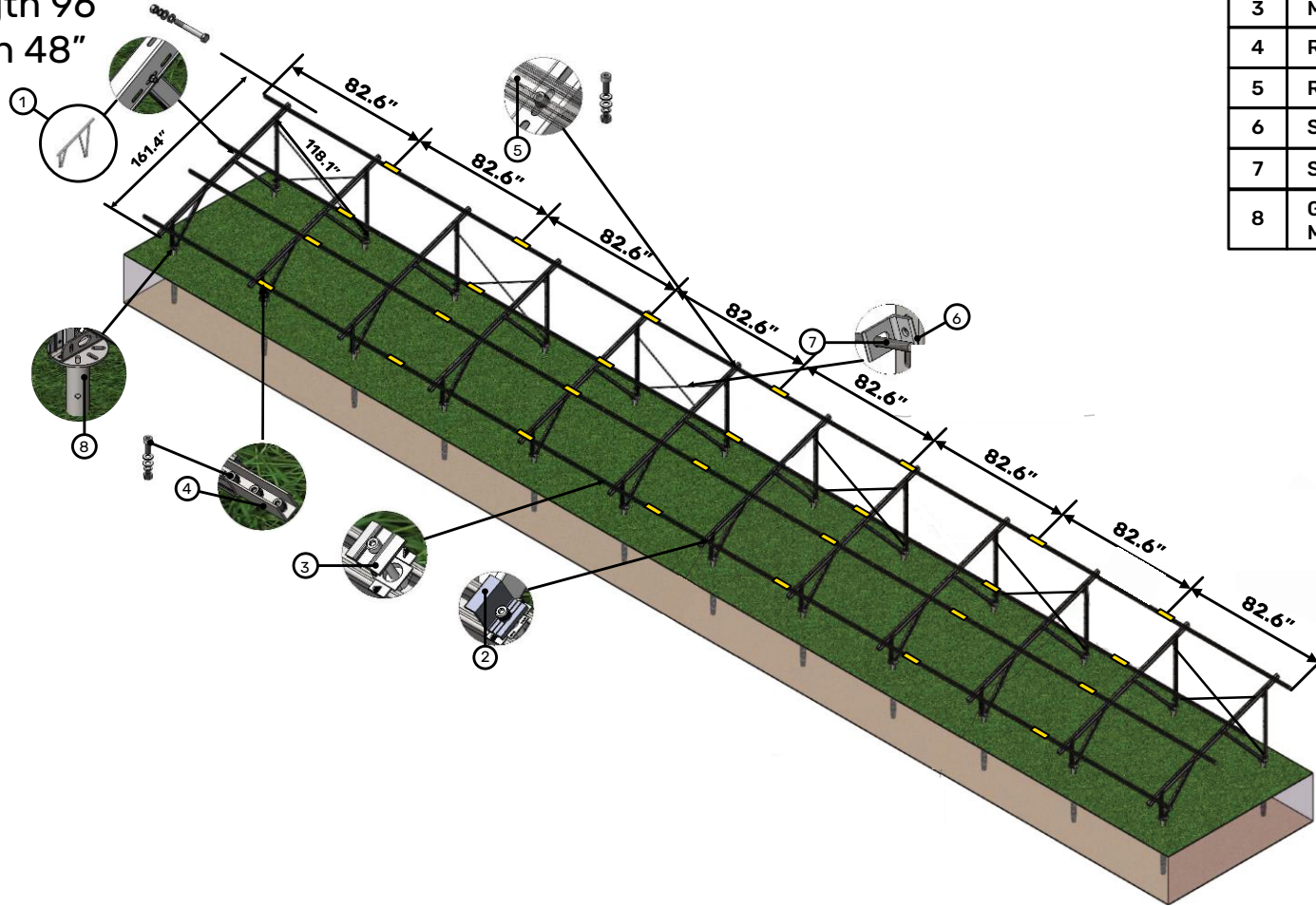

Illustrations are intended for general reference and may not reflect the exact configuration of your design

Mark	Modifivation	Modify by	Doc No.	Data	Des	J. Burton	240918
					Drw		
					Check		
					Craft		
					App		

CHIKOUSA

U2V

2x15 20°

View:

Rate

Page 3

A

B

C

D

30-PANEL HIGH-STRENGTH

Large Format Size Module
 Max Length 96"
 Max Width 48"

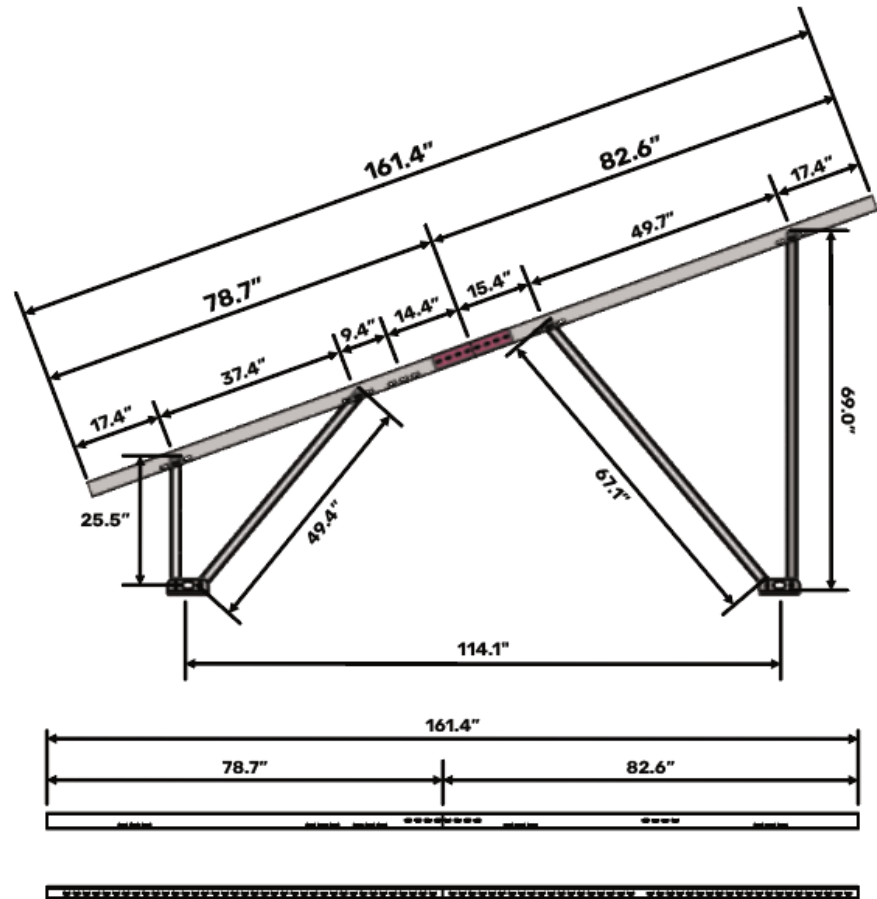

Illustrations are intended for general reference and may not reflect the exact configuration of your design

Mark	Modifivation	Modify by	Doc No.	Data	Des			CHIKOUSA		
					Drw					
					Check					
					Craft					
					App					
							View:	Rate		Page 4

A

B

C

D

30-PANEL HIGH-STRENGTH

Large Format Size Module

Max Length 96"

Max Width 48"

Attachment Distance

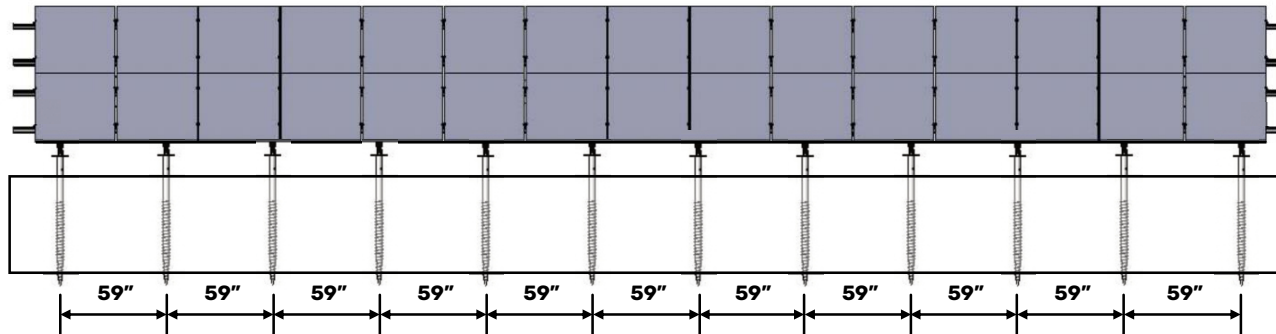

Rail Length

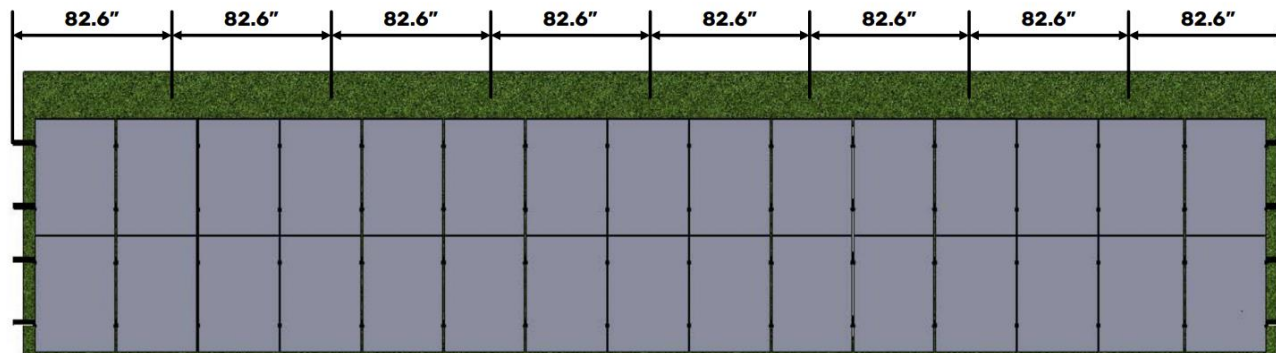

Illustrations are intended for general reference and may not reflect the exact configuration of your design

Mark	Modifivation	Modify by	Doc No.	Data	Des	J. Burton	240918		
					Drw				
					Check				
					Craft				
					App				
								U2V	
								2x15 20°	
View:								Rate	Page 5

A

B

C

D

30-PANEL HIGH-STRENGTH

Large Format Size Module
 Max Length 96"
 Max Width 48"

Foundation/Attachment Layout

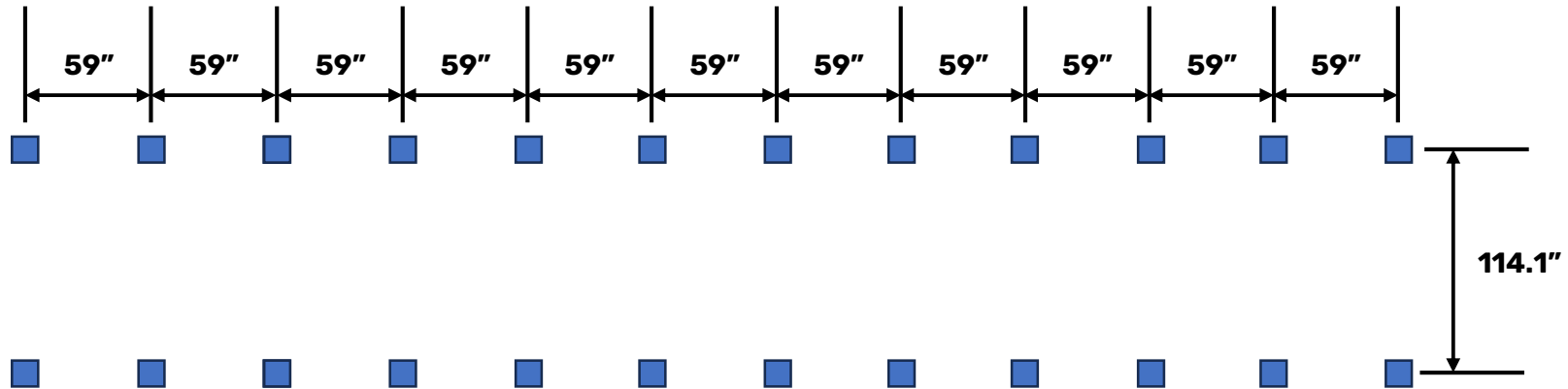

Illustrations are intended for general reference and may not reflect the exact configuration of your design

Mark	Modifivation	Modify by	Doc No.	Data	Des	J. Burton	240918	CHIROUSA
					Drw			
					Check			
					Craft			
					App			
								View:
								Rate
								Page 6

A

B

C

D